

Product Overview

Masonry support is a stainless steel component that transfers the weight of a building's brickwork facade to the building's structure. This reduces the risk of cracking and movement in the facade.

TITAN is an ex-stock masonry support solution comprising a front-loaded shelf angle, brackets, lock washers, shims and bolts. This solution provides structural engineers with an excellent alternative to Welded Masonry Support. The front-fit loading of the masonry support shelf facilitates ease of installation, while the bracket system is designed to accommodate typical build tolerance onsite, ensuring accurate installations.

Brackets, shelf angle and lock washers are manufactured from either 304/304L Austenitic Stainless Steel (1.4301/1.4307) or 316/316L (1.4401/1.4404) on request. Thermal shims are manufactured from A1 fire-rated composite material and stainless steel shims of various thicknesses are available on request.

Enhanced features

- Ex-stock product
- Stainless steel - A1 fire-rated material
- Quick specification using simple load/cavity charts*
- Fast installation facilitated by front-loaded shelf angle
- Onsite adjustability
- EPD: BRE Global Verified

*Refer to [TITAN Declaration of Performance document](#).

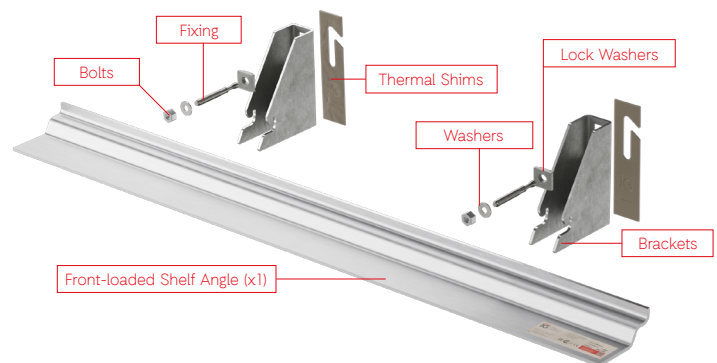

System specifications

IG Masonry Support offers six TITAN systems suitable for concrete and steel framed structures, the design of these systems accommodate masonry loads of up to 4, 6, 8, 10, 12, and 14kN/m, respectively. Standard brackets are available for cavity widths ranging from 50 to 200mm (stocked in 10mm increments). Brackets are simply changed on site to allow for cavity variations.

TITAN System Specification			
System Type	Designed Load (kN/m)	Angle Length (mm)*	Bracket Centres (mm)
TITAN 4	4	1590	800
TITAN 6	6	1390	700
TITAN 8	8	1190	600
TITAN 10	10	990	500
TITAN 12	12	990	500
TITAN 14	14	790	400

Note: Loadings may be restricted by cavity size and bolt type. Please refer to [TITAN Declaration of Performance document](#).

*Allowance for 10mm gap between shelf angles

Fixing options

TITAN can be fixed to:

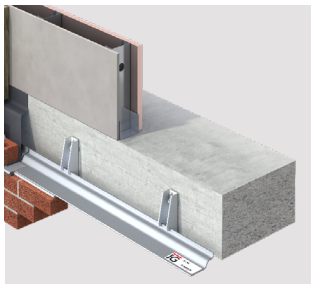

A Concrete slab

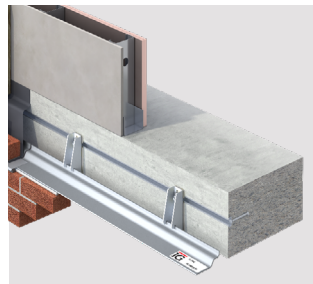

B Cast-in Channel

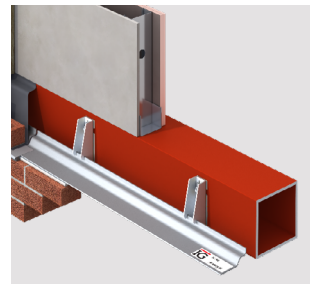

C Box section

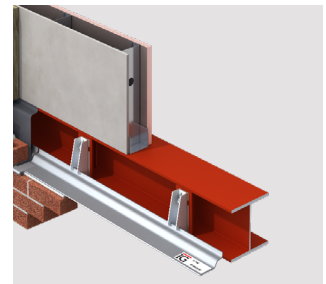

D I-beam with wing plates

Fixing specifications

The fixing is the most important component involved in achieving the design capacity of TITAN. It is crucial that fixings are installed in accordance with the manufacturer guidelines and torque settings (see table below), to ensure the design requirements for the product are met. **Only fixings specified within this document or provided by IG should be used.**

Fixing Specifications			
Fixing Type	Fixing to	Drill Hole Diameter	Torque (Nm)
FAZ II 12/20	Concrete	12	60
FAZ II 12/30	Concrete	12	60
FAZ II 12/50	Concrete	12	60
HD BOLT M12x60	Steel	12	30
SET SCREW M12x60	Steel	14	73.5

Load Bearing Zone

The bracket 'Load Bearing Zone' (ie. the distance between the fixing and the bottom heel of the bracket) must have full contact with the support structure and shims.

Reduction of the Load Bearing Zone will reduce the design capacity of the system and may result in excessive deflection and fixing failure. *Always refer to your Construction Issue Drawings for your project's exact requirements.*

Never allow the heel of the bracket to project below the support structure. If you require the bracket to drop below the support structure, please contact our technical team.

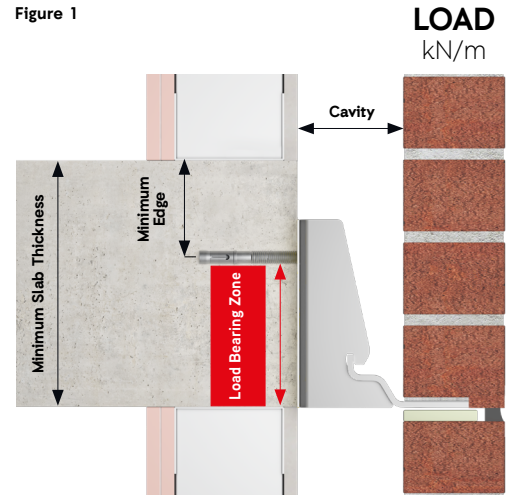

Figure 1 Key

Load Bearing Zone	The distance between the fixing and the bottom heel of the bracket in contact with the backing structure
Slab thickness	The depth of the concrete slab
Cavity	Two masonry walls separated by an air space
Wall ties	Sometimes called 'brick ties'. Used in buildings with cavity walls to tie the two leaves of a cavity wall together

Brickwork overhang

Brickwork overhang must not exceed 1/3 of the brick width. A minimum masonry bearing of 2/3 on the shelf must be maintained unless otherwise stated by the manufacturer. It is therefore recommended that the bricks are positioned close to the back edge of the shelf angle.

Wall ties

Stainless steel wall ties are crucial to the performance of all masonry support systems. The recommended maximum spacing for wall ties is 450mm horizontally and 300mm vertically above the shelf angle.

Compressible filler

It is essential that all soft horizontal joints have a compressible filler installed directly underneath the shelf angle (see Figure 2).

Positioning the shelf

The underside of the shelf angle should be set 2.5mm above the level of the compressible filler (see Figure 2). This will allow for any settlement that may occur as a result of the vertical dead load imposed by the masonry and to accommodate expansion of the brickwork below.

Figure 2



Adjustability

TITAN provides adjustability across all three planes (X,Y & Z), to ensure that building tolerances can be accommodated and contact with structural reinforcing bar can be avoided.

(X) Shimming (Y) Vertical Adjustment (Z) Lateral Adjustment

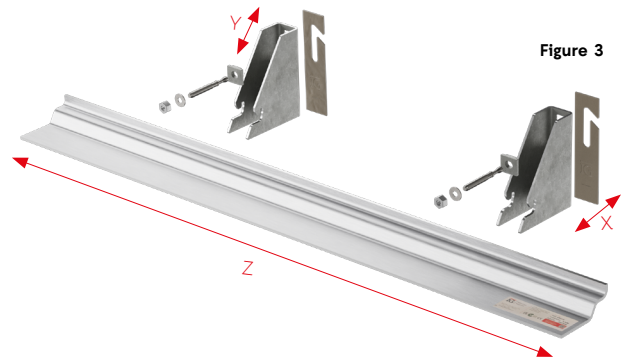
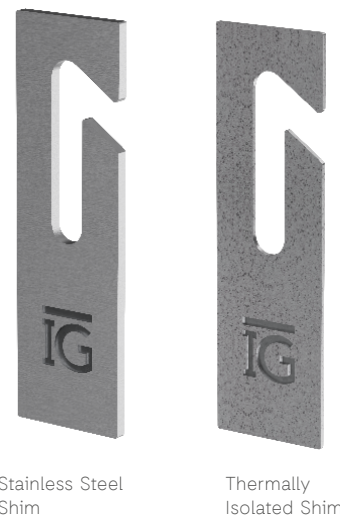

Figure 3

Shimming (X)

To accommodate a small increase in cavity width, shims can be inserted between the support structure and the brackets. Thermal shims are provided as standard to reduce thermal bridging in a thickness of 2mm and stainless steel shims are available to order in a range of thicknesses (3,4,5 and 6mm).

- The standard thickness of shim used per bracket should never exceed the outside diameter of the fixing
- The collective number of shims that can be used should never exceed three
- Shims must support, and come into contact with the full 'Load Bearing Zone' of the bracket against the support structure
- If thicker shimming is required, please contact our technical team.



Vertical adjustment (Y)

Vertical adjustment is offered by means of a toothed lock washer (Figure 4). This lock washer is inserted into the serrated slot in the support bracket. The lock washer can be adjusted vertically to move the bracket higher or lower.

The serrated area at the back of the bracket allows up to 15mm of adjustment in either direction on the vertical plane.

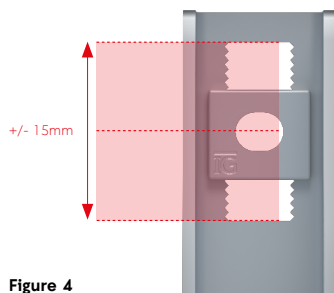

Figure 4

Lateral adjustment (Z)

TITAN is designed to have two brackets per shelf angle (except external corners where three brackets will be introduced). To achieve the correct bracket spacing, add 10mm to the shelf length and then space 1/4-1/2-1/4 along this measurement. The maximum adjustment from these positions is +/- 25mm (Figure 5).

The lock washer also provides lateral adjustment via the oval-shaped hole in the washer. The anchor can be moved laterally to allow for fine adjustment.

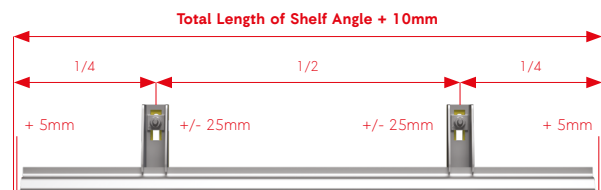

Figure 5

Positioning the bracket

Brackets must be installed at the correct level making sure the back of the bracket ('Load Bearing Zone') is in full contact with the support structure. Only IG shims can be used with TITAN.

Correct and incorrect installation examples are provided in Figure 6.

Figure 6

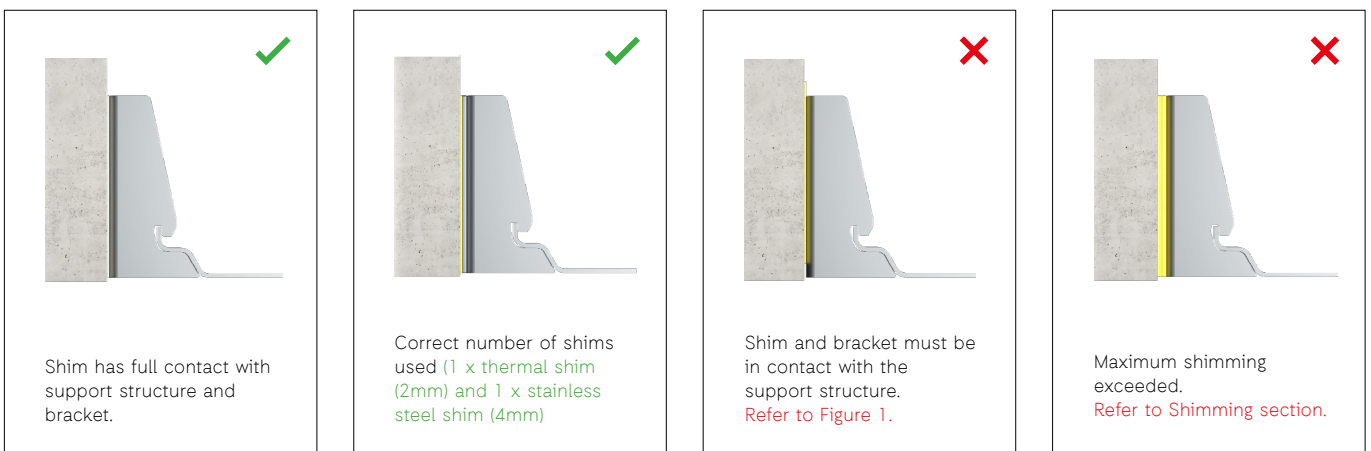

External corners

When installing TITAN at an external corner, you will require two mitred shelf angles. Standard shelf angles can be cut on site to suit project requirements.

Each shelf angle consists of three support brackets and they are positioned as follows:

- 1 Positioned 150mm in from corner of the support structure.
- 2 Positioned a further 150mm in from the centre of the first bracket.
- 3 Positioned towards the other end of the shelf, drawings can be provided upon request.

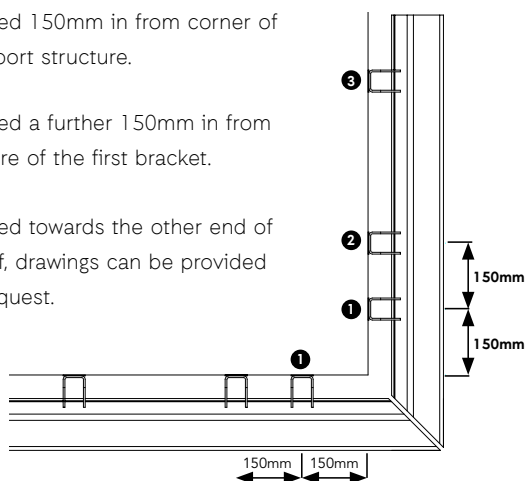

Site cutting

TITAN shelf angles can be cut on site to suit however any cut or reduced length must still be supported by a minimum of two brackets.

The minimum length that the shelf can be trimmed down to is 300mm with a minimum bracket spacing of 150mm.

Figure 7

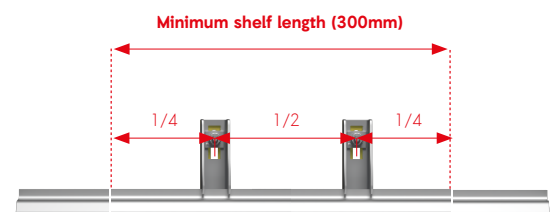

Declaration of Performance (DOP)

IG Masonry Support has a Declaration of Performance for all TITAN systems available. Visit igmasonrystsupport.com/resources for the most up-to-date version.

Required building method

One course of brick should be built on the masonry support shelf angle (which includes a thru-wall flashing and a drip edge) and given adequate time to cure. A further five courses of brickwork should then be built and tied to the structure of the building, again given adequate time to cure. This will allow the masonry to form a rigid structure above the shelf angle. The maximum height of masonry constructed each day above this rigid structure should not exceed 1500mm, giving 1-2 days curing time before any future building.

Bi-metallic corrosion

Bi-metallic corrosion can occur when stainless steel and carbon steel are in direct contact with each other in a damp environment. This can be avoided by isolating the two metals. IG Masonry Support supply a Thermal Shim as standard, which must be located between the back of the bracket and support structure.

Product design and testing

Masonry support falls within the scope of harmonised European Standard BS EN 1090-1:2009 +A1:2011 Execution of steel structures and aluminium structures: Requirements for conformity assessment of structural components. IG Masonry Support comply with all CPR and CE marking requirements of this Standard, including designs to EN 1993 (Eurocode 3) and external certification of factory production controls by an approved body. The company is certified by the BBA and Eurofins to undertake welded fabrication work to Execution Class 2 according to BS EN1090-2:2018.

A1 non-combustible material

All IG Masonry Support's masonry support systems are manufactured from 304/304L Austenitic Stainless Steel (1.4301/1.4307) or 316/316L (1.4401/1.4404) on request. Stainless steel is considered A1 fire-rated without the need for testing in accordance with the guidance of the European Commission Paper 96/603/EC as referenced in BS EN 13501-1:2018.

IG Masonry Support's Thermal Shims are A1 fire-rated and have been tested and classified in reaction to fire in accordance with BS EN 13501-1:2018.

Thermal conductivity

Approved Document L Volume 2 places specific emphasis on the performance of building details and the additional heat losses through linear thermal bridging. To support this requirement, all IG Masonry Support's masonry support systems are manufactured from 304/304L Austenitic Stainless Steel (1.4301/1.4307) or 316/316L (1.4401/1.4404) on request. Stainless steel has among the lowest thermal conductivity of any metal at approximately 15 watts per kelvin per metre. IG also supply a thermal shim as standard with every masonry support system, which must be located between the back of the bracket and the support structure.

Safety

While TITAN units are easy to handle, the components are produced from stainless steel plates and may have sharp edges. Care must be taken when handling units and suitable PPE should be worn at all times. When lifting or carrying a TITAN unit, you should undertake a personal risk assessment, paying attention to the size and weight of the product which is clearly detailed on each product label and pallet delivered.

Disposal

The TITAN system's stainless steel components are fully recyclable, minimising waste and reducing its carbon footprint at the end of its service life. Thermal Shims should be safely disposed of in landfill.

Installation training

Correct installation is essential for the success of each project. Therefore, IG Masonry Support has made every effort to help installers by creating an [easy-to-use installation guide for TITAN](#).

IG Masonry Support also offers onsite installation training and support from its experienced team of structural and civil engineers.

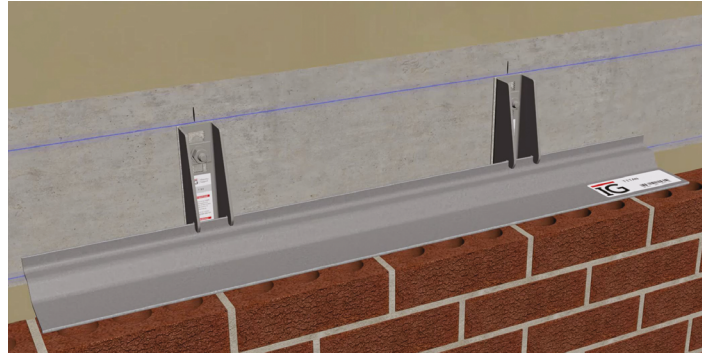

Specifying and ordering

IG Masonry Support's designers and engineers provide a full technical service for the TITAN system, tailored to the requirements of each project.



TITAN Sales and Enquiries

For more information
please contact our Technical Team

+44 (0)1283 200 157

IG Masonry Support Swadlincote

Ryder Close
Cadley Hill Industrial Estate
Swadlincote
South Derbyshire
DE11 9EU

T +44 (0)1283 200 157

E support@igmss.co.uk

IG Masonry Support Cookstown

Ballyreagh Industrial Estate
Cookstown
Co. Tyrone
Northern Ireland
BT80 9DG

T +44 (0)28 8676 0334

E info@igmss.co.uk