

TITAN

Installation Guide



Tools required



Spirit Level



Chalk line / Laser



Tape Measure



Hammer Drill
with Masonry Drill Bit



Lump Hammer



Torque Wrench



Spanner



Pencil

Introduction

TITAN is an ex-stock product and comprises a shelf angle, brackets, lock washers, washers, shims and bolts.



Brackets, shelf angle and lock washers are manufactured from either 304/304L Austenitic Stainless Steel (1.4301/1.4307) or 316/316L (1.4401/1.4404) on request. Brackets are available to suit cavity widths ranging from 70mm up to 200mm in 10mm increments however larger cavity sizes are achievable with the use of our IG Welded Masonry Support system.

For any support required, contact our technical team
support@igmss.co.uk

TITAN

Safety



While TITAN units are easy to handle, the components are produced from stainless steel plates and may have sharp edges. Care must be taken when handling units and suitable PPE should be worn at all times. When lifting or carrying a TITAN unit, you should undertake a personal risk assessment, paying attention to the size and weight of the product which is clearly detailed on each product label and pallet delivered.

Do not use or install damaged TITAN units.

Storage

All factory-wrapped goods received must be stored on a level and cordoned off area so they are clearly visible. Care must be taken when opening the wrapping on the delivered product. All goods must be opened and inspected immediately after delivery. Any irregularities must be reported in writing to IG Masonry Support within 5 days of delivery.

Disposal

The TITAN system's stainless steel components are fully recyclable, minimising waste and reducing its carbon footprint at the end of its service life. Thermal Shims should be safely disposed of in landfill.

Pre-installation check



Before TITAN is installed, the support structure must be checked for alignment and level.

If the support structure is outside the adjustment range detailed in our Product Guide, please consult with our technical team for advice.



To achieve the design capacity of TITAN, the system must be installed in the correct manner.

2 Determine and mark Datum Level

Determine the Datum Level for the heel of the bracket by reviewing the brickwork constructed onsite.

Transfer the Datum Level to the slab edge, mark with a pencil then pull a chalk line through or use a laser level.

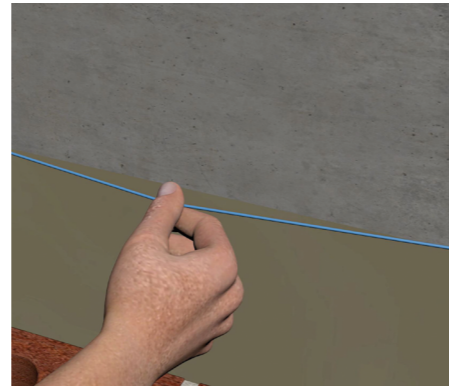
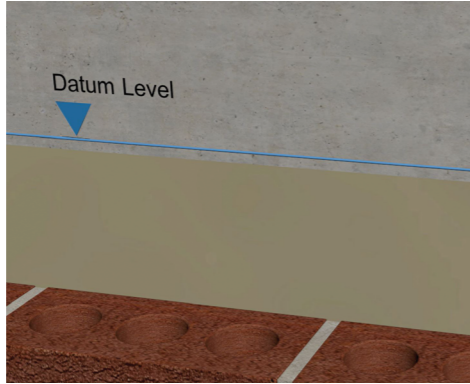

3 Measure bracket height



Measure the height of the supplied bracket.

Note: You must ensure that the brackets have full contact with the support structure and shims. Reduction of the load bearing zone will reduce the design capacity of the system and may result in excessive deflection and bolt failure. (See Diagram 1).

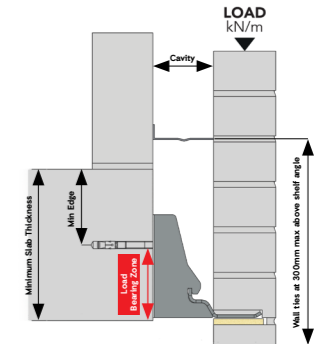
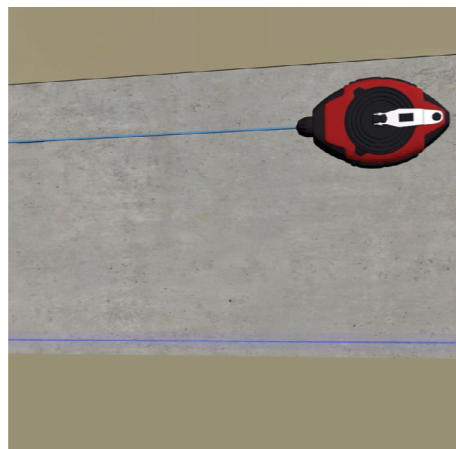
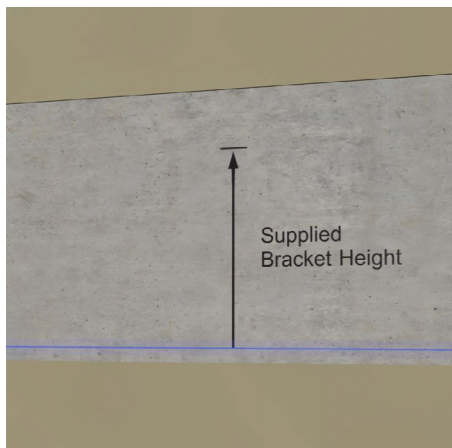

Diagram 1

4 Mark bracket height



Measure up from the Datum Level and mark bracket height with a pencil on the slab face.

Pull chalk line through at this level or laser level.

5 Determine shelf lengths and bracket positions

Refer to the TITAN System Specification table to determine the position of the first bracket, normally dimensioned off a gridline or a slab edge corner.

TITAN System Specification			
System Type	Designed Load (kN/m)	Angle Length (mm)*	Bracket Centres (mm)
TITAN 4	4	1590	800
TITAN 6	6	1390	700
TITAN 8	8	1190	600
TITAN 10	10	990	500
TITAN 12	12	990	500
TITAN 14	14	790	400

Note: Loadings may be restricted by cavity size and bolt type. Please refer to [TITAN Declaration of Performance document](#).

*Allowance for 10mm gap between shelf angles

6 Set out external corners

Set out external corners. You will require two mitred shelf angles. Each shelf angle consists of three support brackets and they are positioned as follows.

Bracket 1 Positioned 150mm in from the corner of the support structure.

Bracket 2 Positioned a further 150mm in from the centre of the first bracket.

Bracket 3 Positioned towards the other end of the shelf. Drawings can be provided upon request.

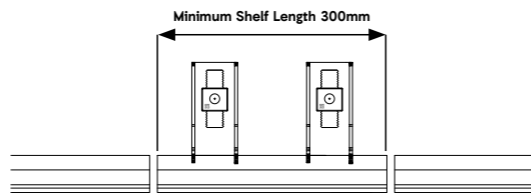
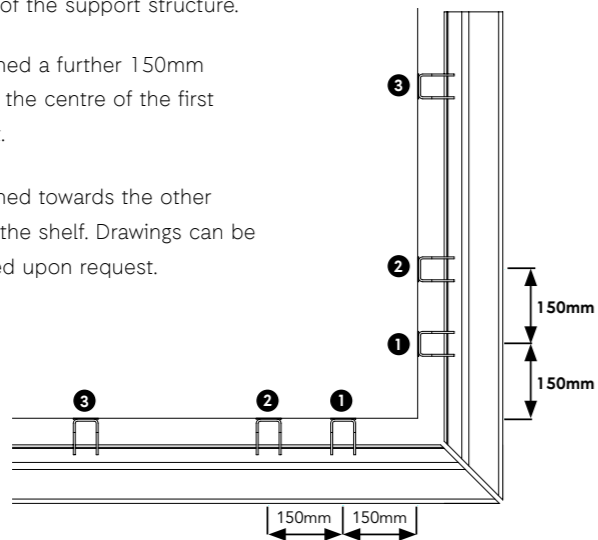

TITAN shelf angles can be cut on site to suit however any cut or reduced length must still be supported by a minimum of 2 brackets.

The minimum length that the shelf can be trimmed down to is 300mm with the minimum bracket spacing of 150mm. If the required space is less than 300mm then two shelves will have to be cut.

7 Mark bracket centres

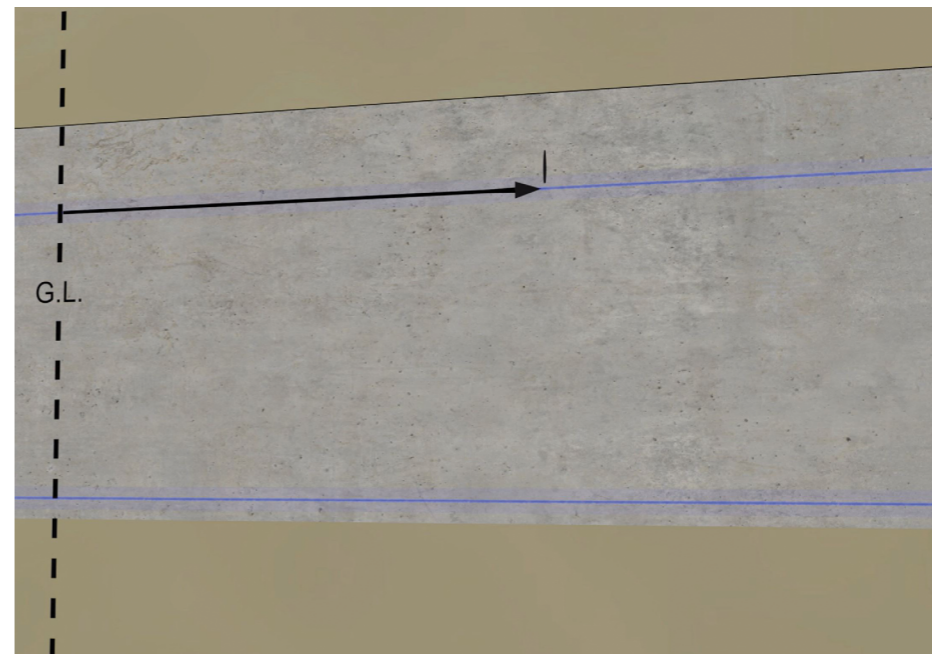

Using this dimension, put a small vertical pencil mark on the top chalk line and transfer the remaining bracket centres all onto the slab edge (refer to TITAN System Specification table at step 5 for measurements).

8

Trace serrated section and mark centre

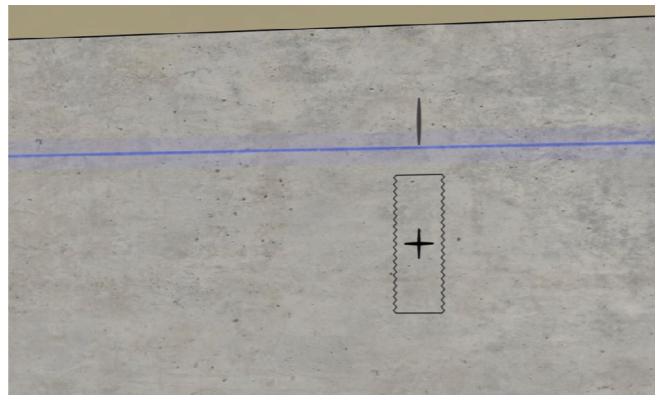
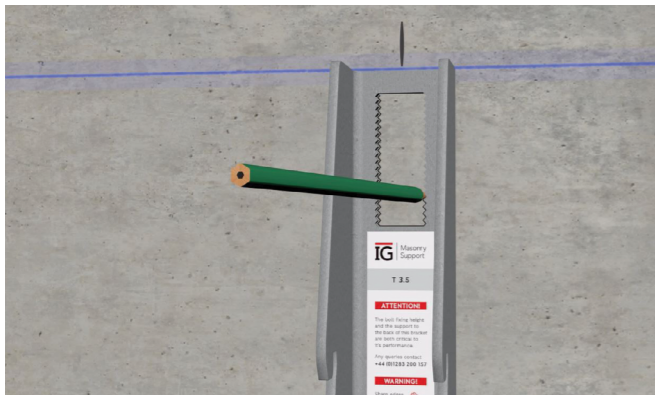

Using one of the brackets supplied, position it level with the top chalk line. Centred on the pencil mark, trace the internal serrated section of the bracket and mark centre with a crosshair.

9

Mark remaining bracket centres

Refer to the TITAN System Specification table for guidance on marking the remaining bracket centres onto the slab edge.

TITAN System Specification			
System Type	Designed Load (kN/m)	Angle Length (mm)*	Bracket Centres (mm)
TITAN 4	4	1590	800
TITAN 6	6	1390	700
TITAN 8	8	1190	600
TITAN 10	10	990	500
TITAN 12	12	990	500
TITAN 14	14	790	400

Note: Loadings may be restricted by cavity size and bolt type. Please refer to [TITAN Declaration of Performance document](#).

*Allowance for 10mm gap between shelf angles

10

Drill holes

BOLT SPECIFICATION

Bolt Type	Fixing To	Drill Hole Diameter	Torque (Nm)	Supplier Name
FBN II 12/20 A4	Concrete	12	35	Fischer
FAZ II 12/20 A4	Concrete	12	60	Fischer
RG M 12x120 A4	Concrete	14	40	Fischer
HD BOLT M12x60	Steel	12	30	Blindbolt
SET SCREW M12x60	Steel	14	73.5	Fit-Lock

Check technical specification on fixings box for embedment and drill depth of the fixing and set hammer drill accordingly.

Drill and blow out all of the holes using a blow-out pump.

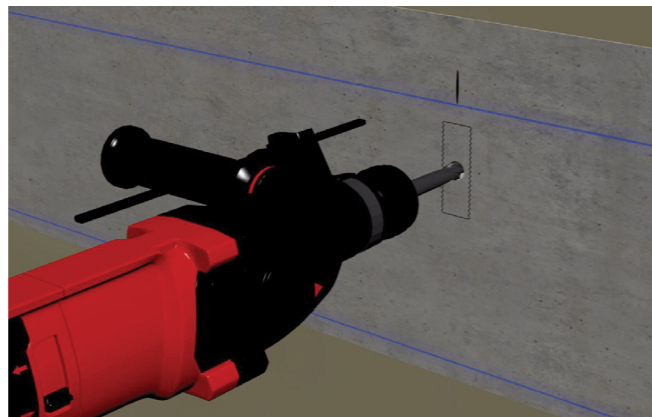

11

Hammer fixings into position

Hammer in each fixing with a lump hammer to the specified embedment depth.

Note: Keep nut positioned to the outermost part of the fixing to prevent any damage when installing.

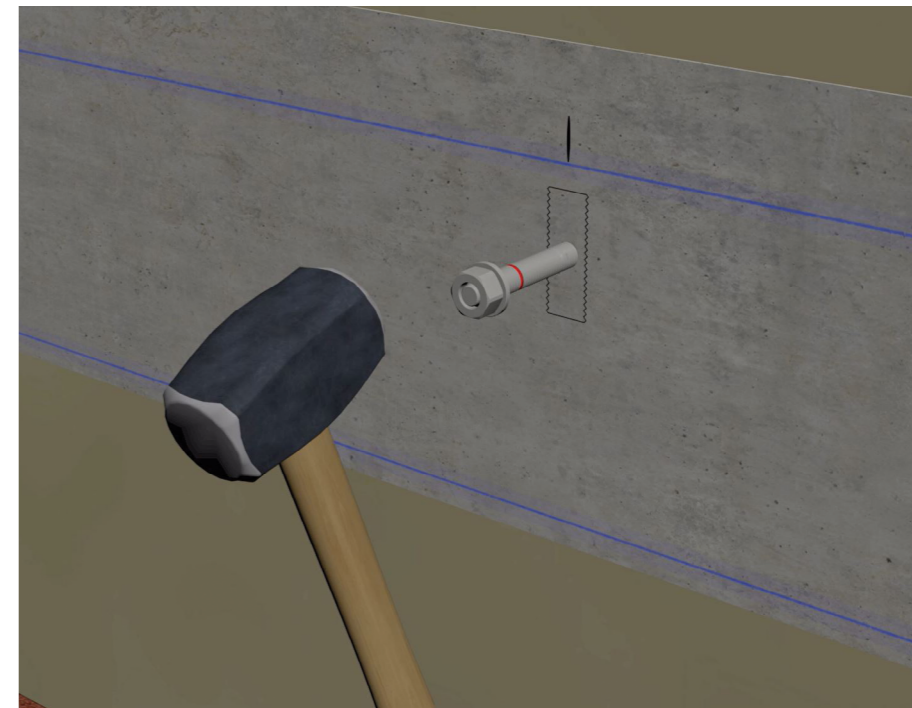

12 Offer up further components

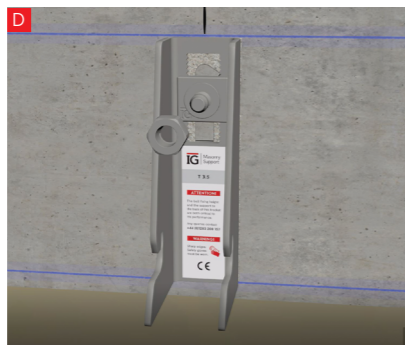
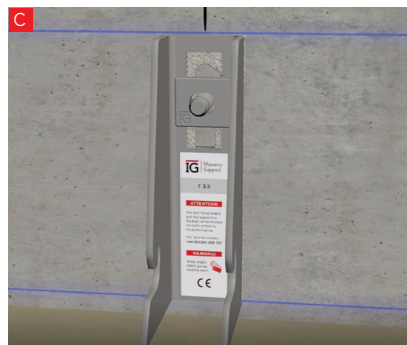
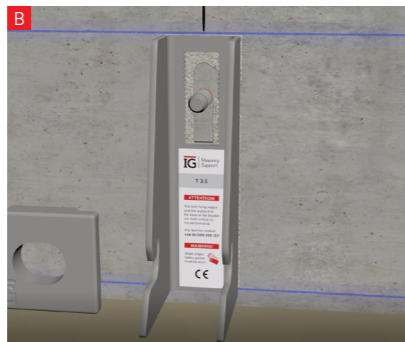
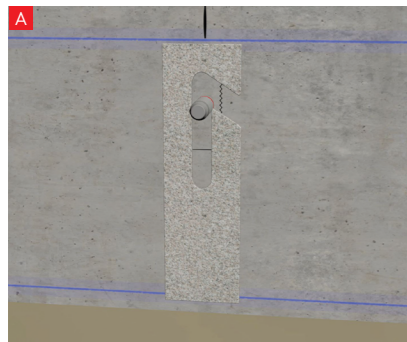

Offer up the shim, bracket, lock washer, washer and nut, and finger tighten (use a spanner if required).

- A** Shim (see below)
- B** Bracket
- C** Lock Washer
- D** Washer & Nut

When installing shims, use the following guidance:

1. Combined thickness of shims per bracket should never exceed the outside diameter of the bolt or 12mm, whichever is less.
2. The collective number of shims used should never exceed 3no.
3. Shims must support, and come into contact with the full load bearing zone of the bracket.

13 Front-load shelf angles

Front-load all shelf angles checking that the alignment is correct and ensure that the shelf is positioned correctly on the brackets.

Use guidance on vertical and lateral adjustment detailed below.

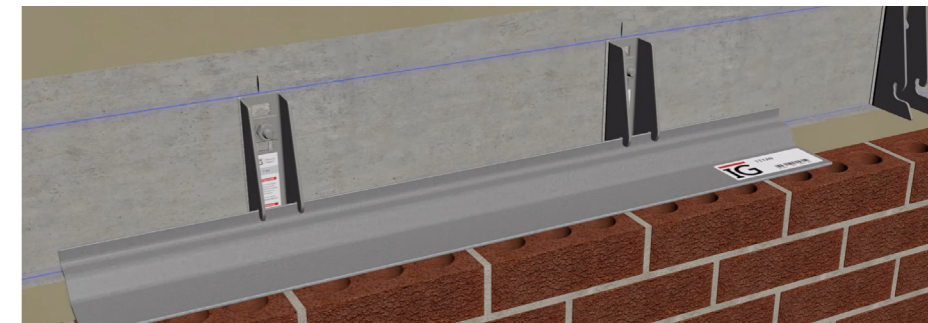

Vertical adjustment

The serrated area at the back of the bracket allows up to 15mm of adjustment in either direction on the vertical plane via the lock washer.

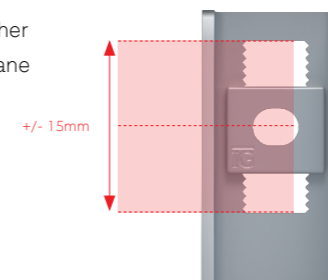

Lateral adjustment

To achieve the correct bracket spacing, add 10mm to the shelf angle length and then space 1/4-1/2-1/4 along this measurement. The maximum adjustment from these positions is +/- 25mm.

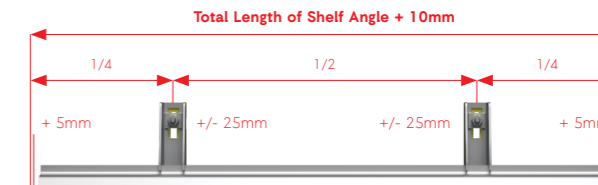

14

Torque fixings

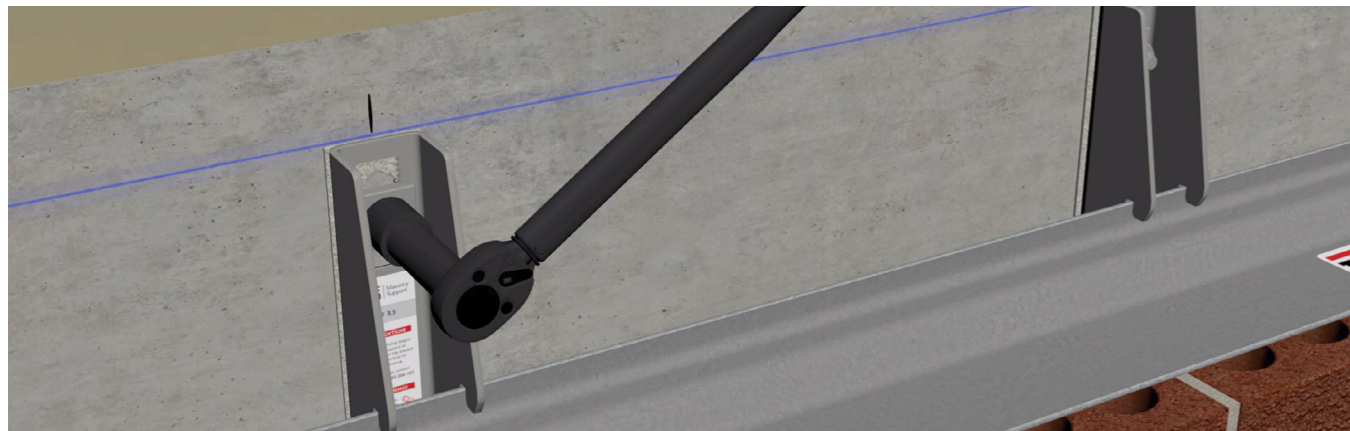

Refer to Bolt Specification table or fixing box for the correct torque settings and adjust torque wrench to suit.

Torque the full run of fixings.

BOLT SPECIFICATION				
Bolt Type	Fixing To	Drill Hole Diameter	Torque (Nm)	Supplier Name
FBN II 12/20 A4	Concrete	12	35	Fischer
FAZ II 12/20 A4	Concrete	12	60	Fischer
RG M 12x120 A4	Concrete	14	40	Fischer
HD BOLT M12x60	Steel	12	30	Blindbolt
SET SCREW M12x60	Steel	14	73.5	Fit-Lock

15

Torque confirmation

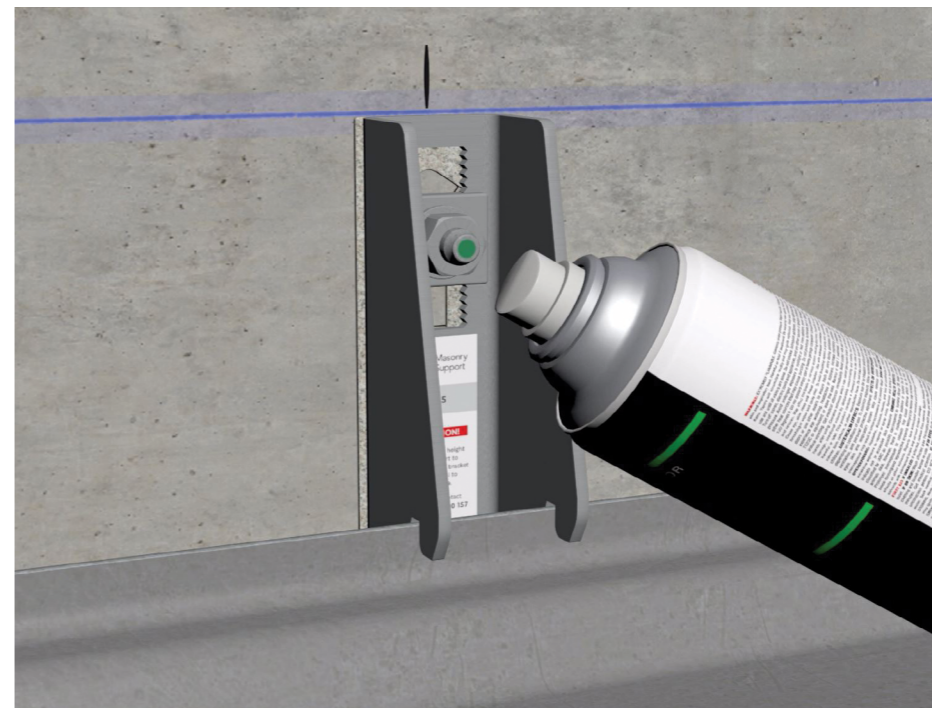

Spray the head of the fixings as you go along, confirming they have been tightened to required torque setting and installation of component is complete.

Once torqued, you must not re-torque.

16

Insert compressible filler

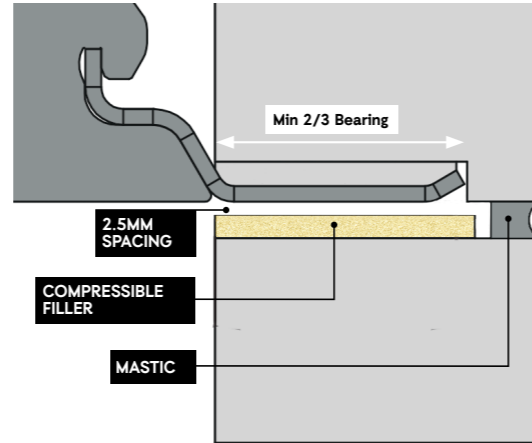
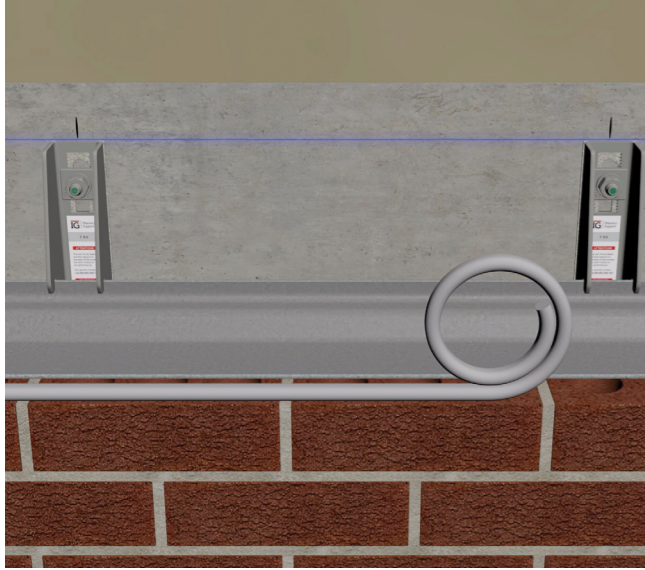

Insert compressible filler to the underside of the masonry support shelf to allow thermal expansion and movement of the brickwork.

The underside of the shelf angle should be set 2.5mm above the level of the compressible filler to allow for any settlement that may occur as a result of the vertical dead load imposed by the masonry and to accommodate expansion of the brickwork below.

17

Continue higher-level brickwork



This concludes the installation of TITAN.

Continuation of higher-level brickwork can commence. Please refer to TITAN Product Guide for 'Required Building Method'.

The IG Masonry Support technical team are on hand to provide support when installing TITAN. To receive support, please call [+44 \(0\)1283 200 157](tel:+44(0)1283200157) or email support@igmss.co.uk

Additional installation materials



For additional installation materials, please visit igmasonrysupport.com or scan the QR code. Alternatively please refer to the supporting documentation supplied with this guide.

Great Britain

Cadley Hill Industrial Estate
Ryder Close, Swadlincote
South Derbyshire, DE11 9EU

—
T +44 (0)1283 200 157
support@igmasonrysupport.com

Ireland

Ballyreagh Industrial Estate
Sandholes Road, Cookstown
County Tyrone, BT80 9DG

—
T +44 (0)28 8676 0334
info@igmasonrysupport.com