



Product overview

IG Masonry Support's Cast-in Channels (CIC) comprise of 3050mm rolled anchor channels with swaged studs, M12 T-head bolts and lock nuts. All components are manufactured from 304 Austenitic Stainless Steel (1.4301) and 316 (1.4401).

A continuous anchor channel embedded into a concrete wall provides high adjustability and enables quick and easy installation of masonry support brackets.



Enhanced features

- Designed in accordance with CEN/TS 1992-4-3
- Facilitate users working with low edge distances
- Load resistances can be improved by using higher concrete strength class on loading
- Shear and tensile resistance in concrete can be improved with additional reinforcement



Key benefits

Installation benefits

The Cast-in Channel solution for fixing masonry support systems to reinforced concrete has the following installation benefits:

- Quick and easy installation of masonry support systems
- No requirement for onsite drilling
- Fixing of masonry support without potential damage to concrete due to drilling
- High load capacity
- Removes the risk of striking reinforcement
- Reduced installation time for masonry support systems

Health and safety benefits

The health and safety benefits fulfilled by the use of Cast-in Channel as a solution for fixing masonry support systems to reinforced concrete over alternative fixing solutions include:

- Installation without the use of electrical tools
- Reduced erection times / working at heights
- No dust from onsite drilling

Product design and testing

The anchor channel has been independently tested by third party organisations and technical approval bodies to evaluate and validate the physical performance and long term durability of all components as well as ensure the products are fit for purpose and conform to regulations.

ETA certified

The anchor channels have been tested in IFBT Leipzig in accordance to the EOTA guidelines and have been awarded an ETA certificate from DIBT (German Institute of Building Technology).

The ETA approval includes thorough specifications on internal and third party quality control of on-going production. Therefore quality assurance is in place to be certain that the quality of the channels correspond with the samples tested during the approval procedure.



ETA-17/0549 & DIBT Z-21.4-2038

The European Technical Approval ETA-17/0549 for the HMPR-CE Anchor Channels was issued by the Deutsches Institut für Bautechnik (DIBt) in 2024.

This new approval is valid on all states of Europe. An ETA catalogue is available which includes the dimensioning of the anchor channels in accordance with the new European standards series CEN/TS 1992-4-3 "Design of fastenings for use in concrete - Anchor Channels."

Eurocodes

The channels are Eurocode compatible and are designed and dimensioned according to CEN/TS 1992-4 standard in combination with the approved loadings in the ETA approval.

ISO 9001:2015

Quality production with strict control according to European requirements. Management and service quality is certified by [BS EN ISO 9001:2015 - Quality Management Systems](#).



Product range

Cast-in Channels are available in a range of sizes that will support line loads up to 27kN/m (unfactored). This will cover most masonry support applications.

Supplied in 3050mm lengths the channels are made from stainless steel (A2) 1.4301.

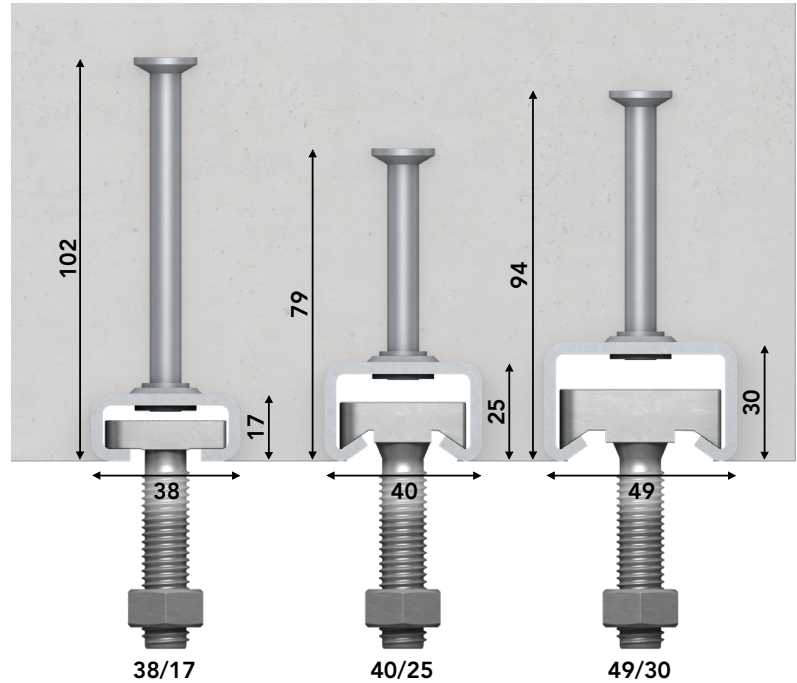

Minimum edge distances and thickness

Depending on the channel type, anchor studs must be positioned at a minimum distance from the component edges.

The minimum spacing of T-head bolts according to the table below must be adhered to.

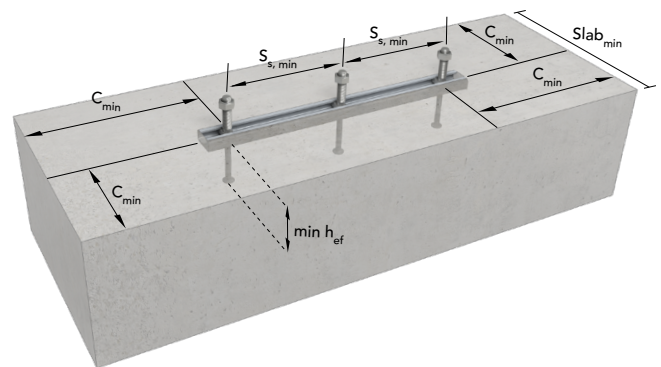

Cast-In Channel Type		38/17-167	40/25	49/30
Min. Spacing of Bolts (mm)	S_{s, min}	150mm	150mm	150mm
Min. Anchor Depth (mm)	min h_{ef}	102mm	79mm	94mm
Min. Edge Distance (mm)	C_{min}	50mm	50mm	75mm
Min. Slab Thickness (mm)	Slab_{min}	100mm*	100mm*	150mm*
Min. Stud Distance (mm)		167mm	250mm	250mm

* Reduced Loading

Installation

Correct installation is essential for the success of each project. Therefore, we have made every effort to help installers by creating an [easy-to-use installation guide for Cast-in Channel](#).



HTB T-Head Bolts installation

All Cast-in Channels are designed and supplied with M12 Stainless Steel T-Head Bolts.

- T-head bolts are installed with the elongated head aligned with the channel, allowing the bolts to be inserted into the channel opening
- The T-head bolts are then rotated by 90 degrees so that the elongated heads are locked in place
- The IG Masonry Support system can then be installed onto the bolts in the normal manner
- The bolts are then torqued in accordance with the below table.

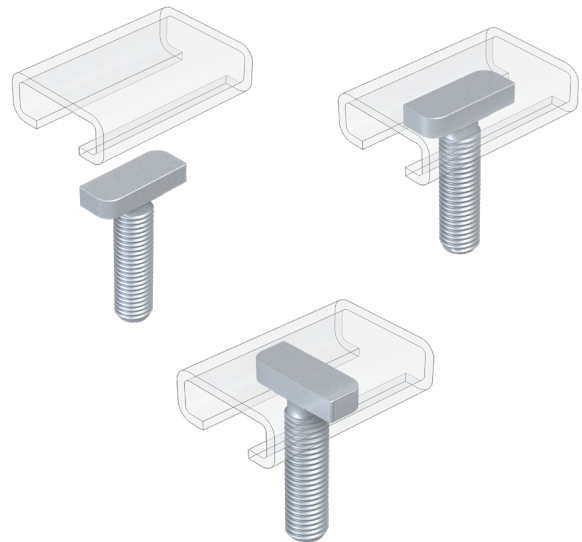

Cast-in Channel Type	T-Head Bolt Diameter (mm)	Setting Torque (Nm)
38/17-167	M12	50
40/25	M12	50
49/30*	M12	50

* 49/30 Cast-in Channel is only specified in extremely high loading situation.

A1 non-combustible material

All IG Masonry Support's masonry support systems are manufactured from 304/304L Austenitic Stainless Steel (1.4301/1.4307) or 316/316L (1.4401/1.4404) on request. Stainless steel is considered A1 fire-rated without the need for testing in accordance with the guidance of the European Commission Paper 96/603/EC as referenced in BS EN 13501-1:2018.

Safety

While Cast-in Channels are easy to handle, the components are produced from stainless steel plates and may have sharp edges. Care must be taken when handling units and suitable PPE should be worn at all times. When lifting or carrying a Cast-in Channel, you should undertake a personal risk assessment, paying attention to the size and weight of the product which is clearly detailed on each product label and pallet delivered.

Disposal

Cast-in Channel's stainless steel components are fully recyclable, minimising waste and reducing its carbon footprint at the end of its service life.

Installation training

IG Masonry Support provides onsite installation training and support from its experienced team of structural and civil engineers.

Specifying and ordering

IG Masonry Support's designers and engineers provide a full design service for the Cast-in Channel system, tailored to the requirements of each project.



Cast-in Channel Sales and Enquiries

For more information
please contact our Technical Team

+44 (0)1283 200 157

IG Masonry Support Swadlincote

Ryder Close
Cadley Hill Industrial Estate
Swadlincote
South Derbyshire
DE11 9EU

T +44 (0)1283 200 157
E support@igmss.co.uk

IG Masonry Support Cookstown

Ballyreagh Industrial Estate
Cookstown
Co. Tyrone
Northern Ireland
BT80 9DG

T +44 (0)28 8676 0334
E info@igmss.co.uk