



BRICK SLIP LINTEL (BSL) Installation instructions

(Single leaf Lintel)

! IG Brick Slip Lintels must be installed in the correct manner to achieve the design capacity of the lintel.

SAFETY PRECAUTIONS

- While IG Brick Slip Lintels are easy to handle, the components are produced from sheared plates and may have sharp edges. Care must be taken when handling Brick Slip Lintels and suitable equipment should be worn at all times.
- When lifting or carrying a BSL undertake a personal risk assessment paying attention to the size and weight of the product. To avoid lifting strains and product damage all BSL products must be lifted by at least two people or alternatively by mechanical means.
- **DO NOT** use or install damaged lintels.

STORAGE (FRAGILE GOODS)

- IG Brick Slip Lintels are fragile and the finished product must be stored in the correct manner. All factory wrapped goods received must be stored on a level surface and cordoned off so that they are clearly visible. Care must be taken when opening the wrapping on the delivered product. All goods must be opened and inspected immediately after delivery. Any irregularities must be reported, in writing, within 5 days to IG Masonry Support Systems. It is the manufacturer's recommendation that the goods on site should be covered. This cover and protective wrapping should only be removed prior to installation.

MATERIALS

Pre-galvanised Steel:
DX51D + Z600 MAC
BS EN 10346 : 2009

Or

Stainless Steel:
Grade 304 or 316
BS EN 10028-7 : 2007

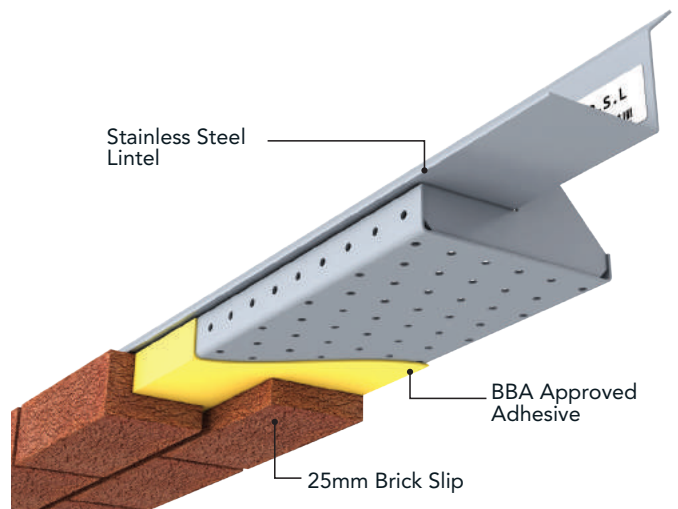

! IG Brick Slip Lintels must be installed in the correct manner to achieve the design capacity of the lintel.

BRICK SLIP DETAIL

IG Brick Slip Lintels (BSL) with a stretcher bond pattern are supplied with an additional brick per opening width. This allows the installer to adjust the location of the BSL to match the existing bond pattern already constructed on site (see image 1, 2 & 3).



Image 1

Typical front view of an IG Brick Slip Lintel to suit a five brick wide 1135mm opening.

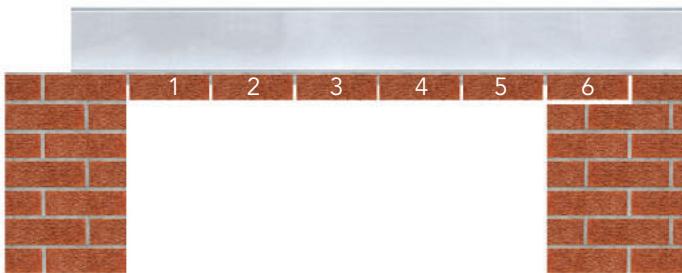

Image 2

IG Brick Slip Lintel installed on a full brick opening.



Image 3

IG Brick Slip Lintel installed on a half brick opening.

! Brick 6 in image 2 & brick 1 & 6 in image 3 must be pointed after installation and **NOT** bedded on mortar during the installation of the lintel.

WALL TIES

Wall ties are crucial to the performance of the BSL. Wall ties should be positioned at a maximum horizontal spacing of 450mm and should be placed within 300mm above the horizontal support.

DISPOSAL

Ensure that all IG packaging and waste are disposed of responsibly. Due care must be given to the environmental impact of the disposal method.

INSTALLATION OF THE IG BRICK SLIP LINTEL

- 1 Refer to approval drawings before installing any Brick Slip Lintels making sure the correct BSL is being positioned in the correct location.
 - 2 Brick Slip Lintels should be installed with a minimum end bearing of 150mm, bedded on mortar and levelled along its length and across its width.
 - 3 Ensure that the structural opening matches the clear opening specified on the drawing.
 - 4 The masonry above the lintel should be built in accordance with BS EN 1996-2:2006.
 - 5 Ensure the lintel is installed as per the correct bond pattern as explained in image 1, 2 & 3.
 - 6 Five courses of brickwork should be built on the lintel support (including the DPC) and tied to the internal structure, giving adequate time to cure. This will allow the masonry to form a rigid structure above the BSL. The maximum height of masonry constructed each day above this rigid structure should not exceed 1500mm giving 1-2 days curing time before any further building.
 - 7 Once the initial load (5 courses) has been laid on top of the lintel all the joints in the BSL can be pointed.
 - 8 Propping a BSL is sometimes practiced to facilitate speed of construction. A prop should only be introduced after the initial masonry load has been applied to the lintel. Care must be taken when propping to ensure that the brick slip soffit remains undamaged. When propping a BSL place a horizontal timber bearer and a dense foam packer along the underside of the lintel. A suitable* prop should be secured into place at a maximum of 1200mm centres (see image 4).
- *Suitability of props is the responsibility of the site manager.
- 9 **DO NOT** cut or modify the BSL.
 - 10 Point loads should not be applied directly onto the lintel. There should be a minimum of 150mm of masonry between any point loads and the BSL.

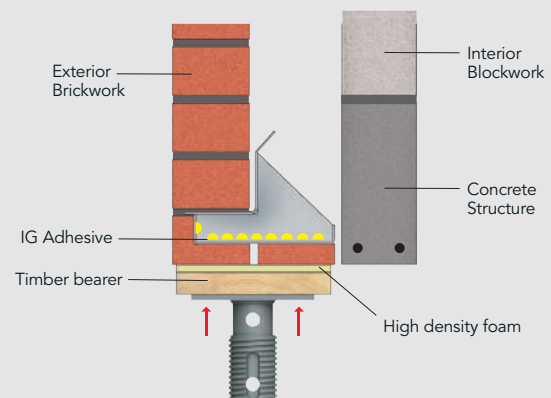

Image 4

Example of propping in a typical wall construction

IG | Masonry Support

MASONRY SUPPORT HOTLINE

01283 200 157

028 8676 0334

Email: support@igmss.co.uk