

BETTER BY  
DESIGN

**B.O.S.S.**<sup>®</sup>  
BRICK ON SOFFIT SYSTEM

BRICK ON SOFFIT SYSTEM INSTALLATION INSTRUCTIONS

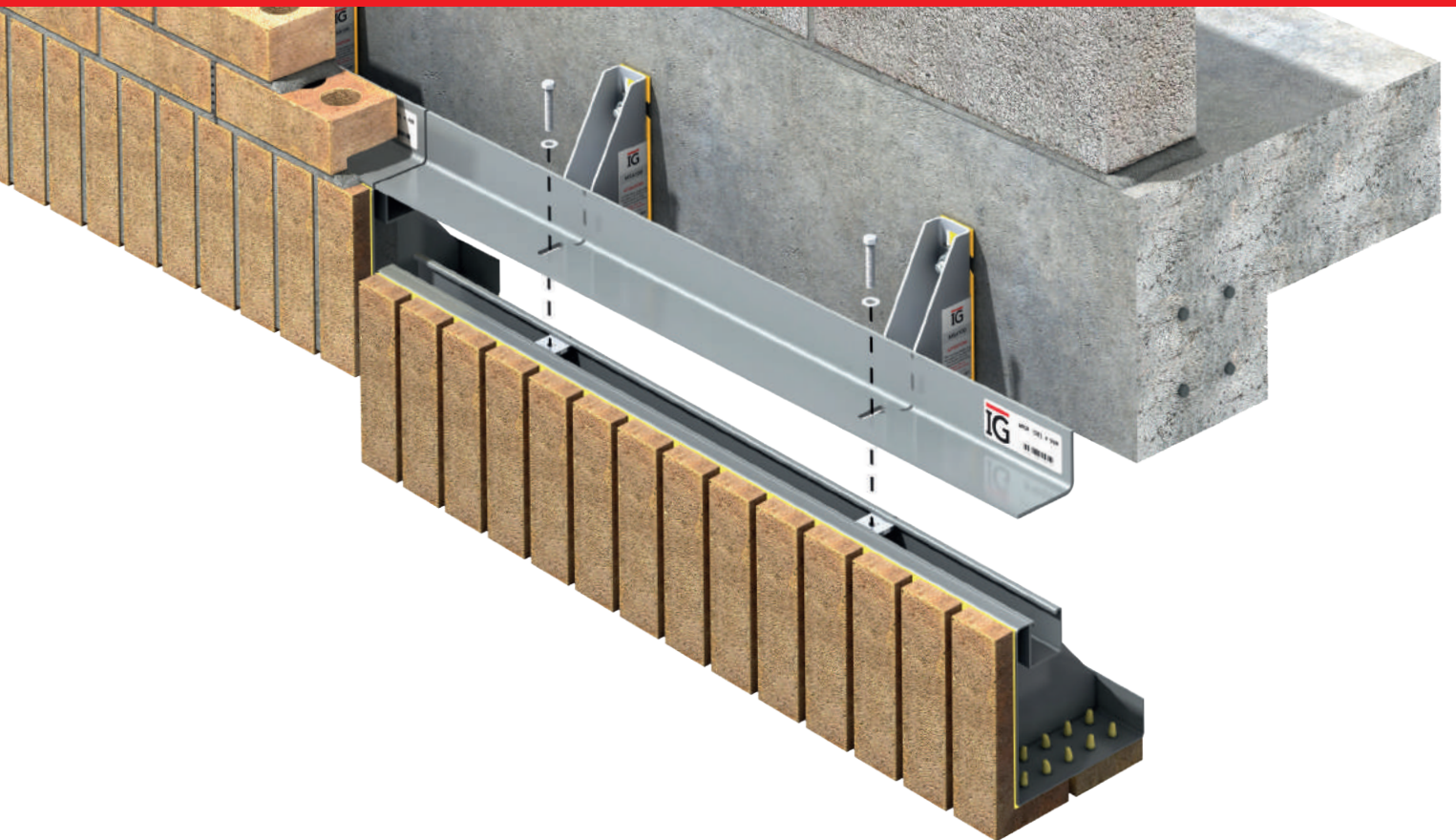

## KEY CONSIDERATIONS FOR CORRECT INSTALLATION

**!** To achieve the design capacity of the product, it must be installed in the correct manner.

### SAFETY PRECAUTIONS

While IG B.O.S.S. units are easy to handle the components are produced from sheared plates and may have sharp edges. Care must be taken when handling B.O.S.S. units and suitable workwear should be worn at all times.

When lifting or carrying a B.O.S.S. unit undertake a personal risk assessment paying attention to the size and weight of the product. To avoid lifting strains and product damage all B.O.S.S. products must be lifted by at least two people or alternatively by mechanical means.

**DO NOT** use or install damaged B.O.S.S. units.

### STORAGE OF FRAGILE GOODS

Unpointed brick slips are fragile therefore B.O.S.S. units must be stored in the correct manner. All factory wrapped goods received must be stored on a level and cordoned off area so that they are clearly visible. Care must be taken when opening the wrapping on the delivered product. All goods must be opened and inspected immediately after delivery. Any irregularities must be reported in writing, within 5 days of delivery to IG Masonry Support Systems. It is the manufacturers recommendation that the goods onsite should be covered. This cover and protective wrapping should only be removed prior to installation.

### DISPOSAL

Ensure that all IG packaging and waste is disposed of responsibly. Due care must be given to the environmental impact of the disposal method.

Table 1

### BOLT SPECIFICATION

Bolt Type	Fixing To	Drill Hole Diameter	Torque (Nm)	Supplier Name
FBN II 12/20 A4	Concrete	12	35	Fischer
FAZ II 12/20 A4	Concrete	12	60	Fischer
RG M 12x160 A4	Concrete	14	40	Fischer
HD BOLT M12x60	Steel	12	30	Blindbolt
SET SCREW M12x60	Steel	14	73.5	Fit-Lock

### MATERIALS

#### Stainless Steel:

Grade 304  
BS EN 10028-7 : 2007

#### Brick

As specified by site

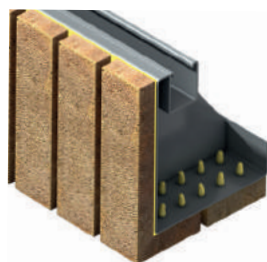

## LOAD BEARING ZONE ILLUSTRATION

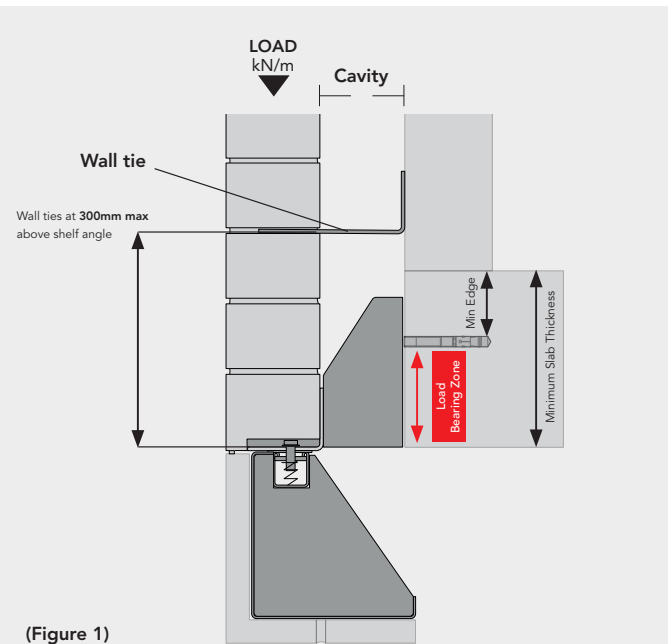

(Figure 1)

Key considerations for correct installation.

### LOAD BEARING ZONE

Please note the load bearing zone in **Figure 1**. The bracket load bearing zone (ie. the distance between the bolt and the bottom heel of the bracket) must have full contact with the support structure and shims. Reduction of the load bearing zone will reduce the design capacity of the system and may result in excessive deflection and bolt failure.

**Never allow the heel of the bracket to project below the support structure. NB: If you require the bracket to drop below the support structure please contact the IG technical team.**

### BRICKWORK OVERHANG

Brickwork overhang must not exceed 1/3 of the brick width. A minimum masonry bearing of 2/3 on the shelf must be maintained unless otherwise stated by the manufacturer. It is therefore recommended that the bricks are positioned close to the back edge of the shelf angle.

### WALL TIES

Stainless steel wall ties are crucial to the performance of all masonry support systems. Wall ties should be positioned at a maximum horizontal spacing of 450mm and should be placed within 300mm above the shelf angle (**Figure 1**).

## IMPORTANT

### POSITIONING THE BRACKET

Brackets must be installed at the correct level making sure the back of the bracket (load bearing zone) is in full contact with the support structure.

# B.O.S.S. INSTALLATION INSTRUCTIONS

## WMS & B.O.S.S.

IG Masonry support supplies the complete system that makes up the B.O.S.S. technology. B.O.S.S. requires IG Welded Masonry Support (WMS) units to be installed across the opening. B.O.S.S. units are then bolted to the underside of IG's WMS.

## ADJUSTABILITY

IG's WMS combined with B.O.S.S. offers adjustability in all three planes as shown in **Figure 2**. The WMS system offers two planes of adjustment (x & y) and B.O.S.S. offers three planes as noted below (x, y & z) (**Figure 3**).

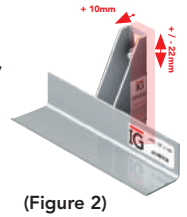

(Figure 2)

## LATERAL ADJUSTMENT (z)

Lateral adjustment is achieved by utilising the channel in the B.O.S.S. unit. The B.O.S.S. unit can be moved +/- 25mm left or right on the fixed welded masonry support system.

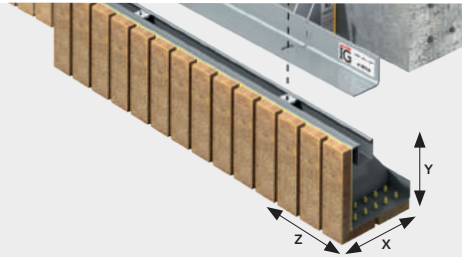

(Figure 3)

## SHIMMING (x)

To accommodate a small increase in cavity width, shims can be inserted between the support structure and the brackets (**Figure 5**). Shims are available in 2mm and 6mm thicknesses.

The combined thickness of shims used per bracket should never exceed the outside diameter of the bolt or 12mm, whichever is less. The collective number of shims that can be used should never exceed three number shims. Shims must support, and come into contact with the full load bearing zone of the bracket. 2mm Shims are provided as standard, 6mm Shims are available upon request.

One 2mm shim should be used as standard on every bracket to reduce thermal bridging.

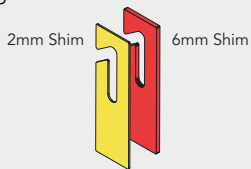

## EASY ONSITE "OFF PLUMB" ADJUSTMENT

IG Masonry Support can provide its patented wedged shim to accommodate for the following scenario; when the support structure is not vertical.

IG's wedged shim can be rotated 180° to accommodate for tilt in either direction. The wedged shim can also be packed one on top of the other to create a larger wedge. A maximum number of 3 wedges can be placed behind one bracket. The wedged shim must fully support the load bearing zone of the bracket at all times. At its largest point maximum shimming must not exceed 12mm or the outside diameter of the bolt, whichever is less.

Each shim offers 1.5° alignment.



## VERTICAL ADJUSTMENT (y)

Vertical adjustment is offered by means of a toothed Lock Washer (**Figure 4**). This Lock Washer is inserted into the serrated slot in the support bracket. The Lock Washer can be adjusted vertically to move the bracket higher or lower.

The serrated area at the back of the bracket allows up to 22mm of adjustment in either direction on the vertical plane. The Lock Washer also gives fine adjustment by rotating it through 180°; this is achieved by the offset hole in the lock washer.

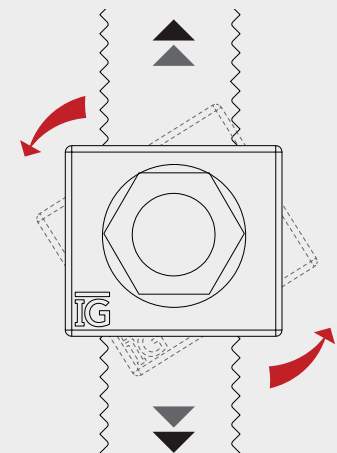

(Figure 4)

## SHIMMING

(Figure 5)

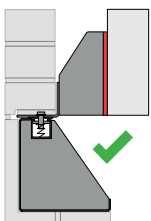

Bracket fully supported

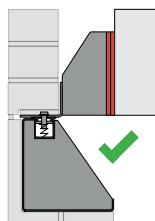

Maximum shimming not exceeded

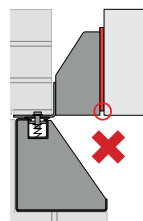

Shim must fully support the bracket

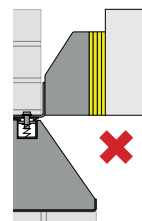

Do not exceed maximum shimming

## B.O.S.S. INSTALLATION INSTRUCTIONS

**B.O.S.S.**  
BRICK ON SOFFIT SYSTEM

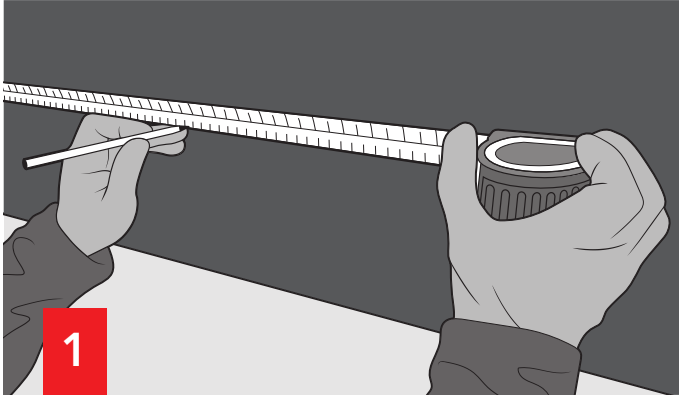

Mark bolt hole centres on the support structure as per the welded masonry support unit requirements.

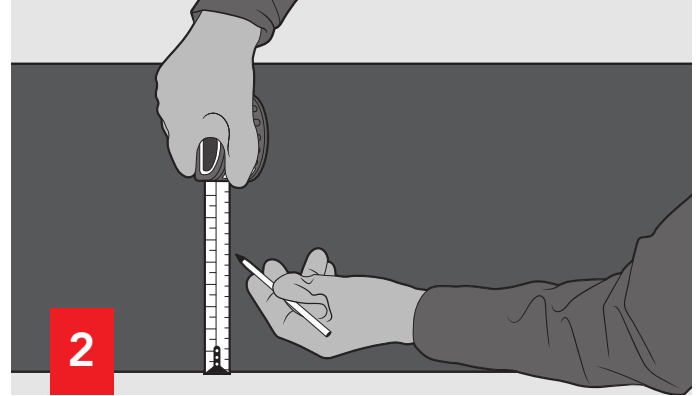

Ensure distance from the bottom of the support structure is per technical drawings. If unsure please consult IG technical team. This is critical.

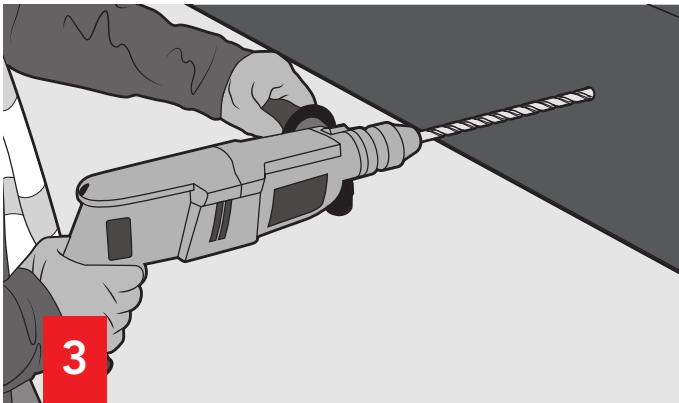

Drill bolt hole in support structure at the marked heights and widths.

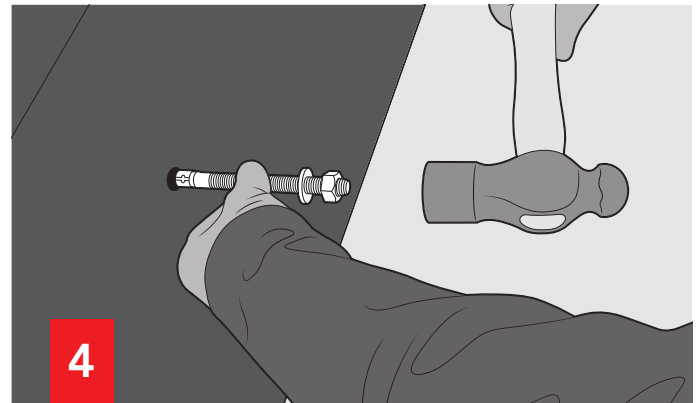

Clean bolt hole and ensure it is free from debris. Insert bolt as indicated in technical drawings.

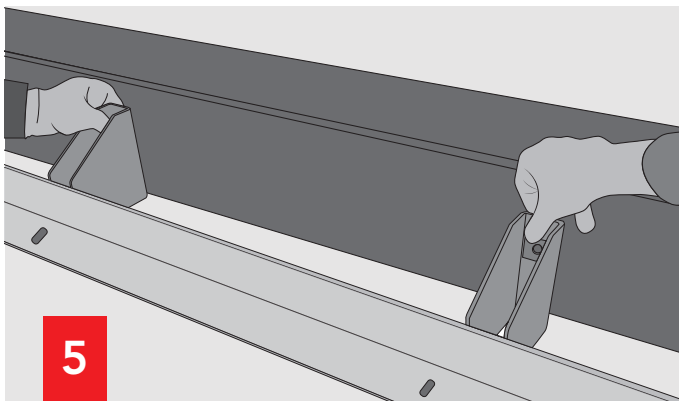

Offer up WMS unit and locate the bolts within the serrated gap at the back of the bracket.

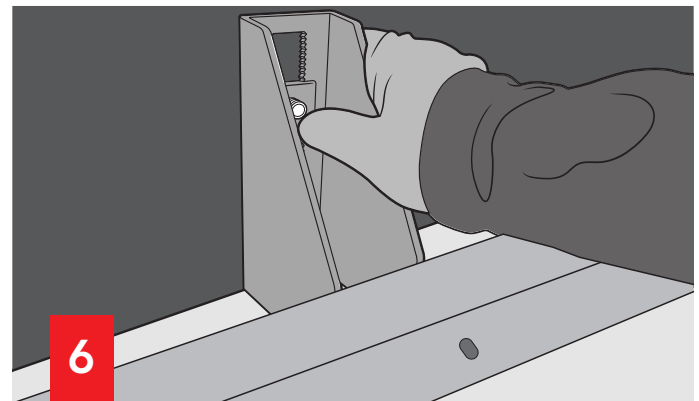

Locate serrated lock washer onto bracket at the preferred height and place bracket onto bolt.

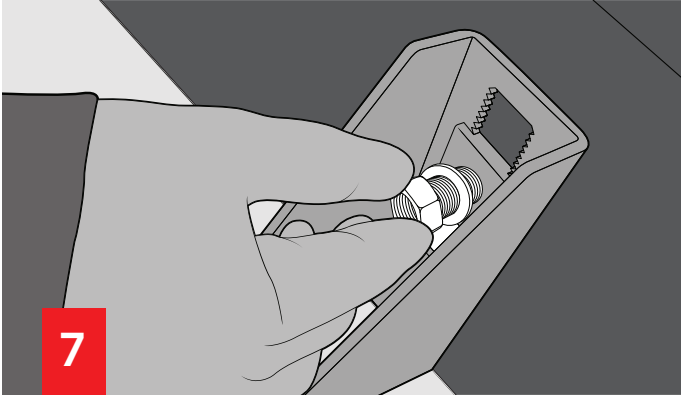

7

Locate nut and washer over bolt.

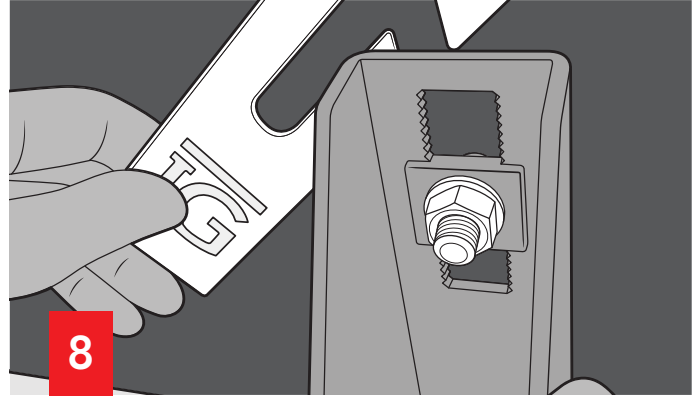

8

If adjustment and shimming is required only use IG shims. The design of the IG shim allows the installer to hook the shim into position even when the bolt and lock washer are located.

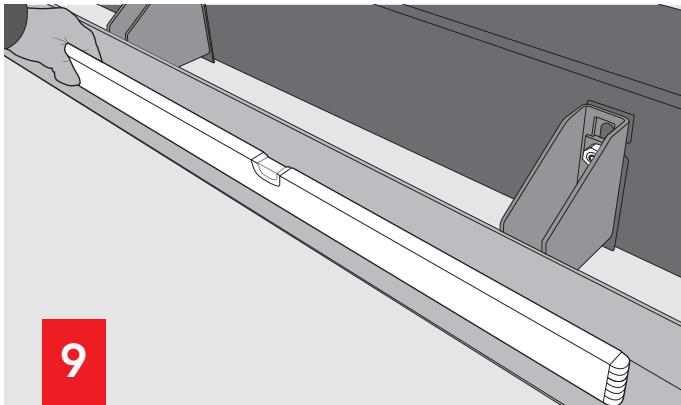

9

Ensure WMS angle is level.

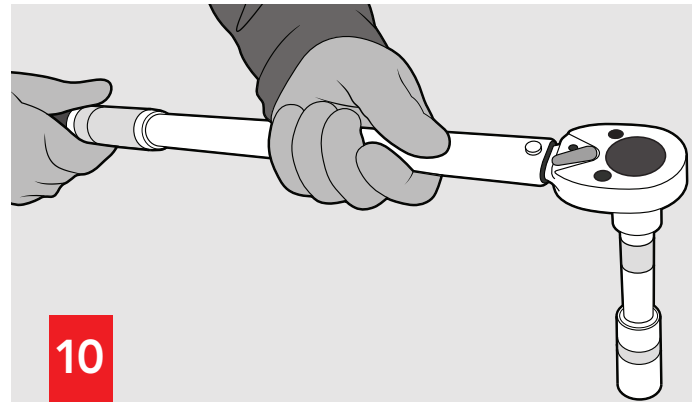

10

Use a torque wrench to torque bolts to the specified value. Ensure torque setting on wrench is set at the specified value.

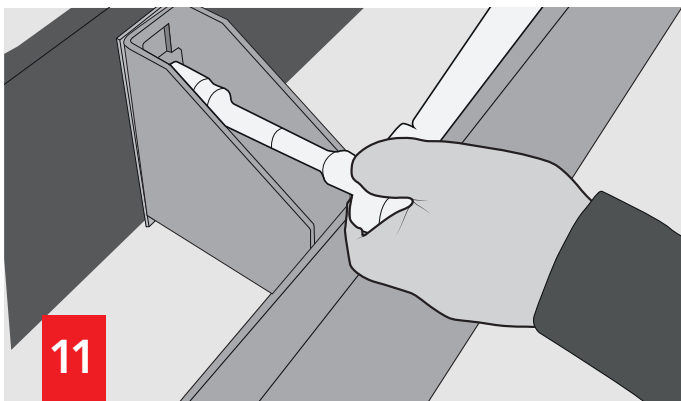

11

Tighten bolts.

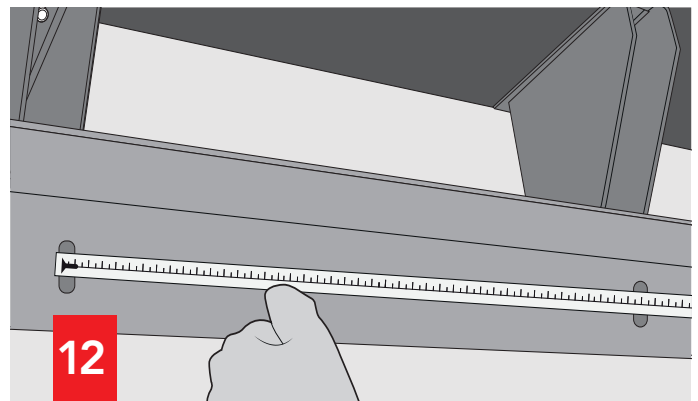

12

Measure centres of slotted holes in WMS angle.

## B.O.S.S. INSTALLATION INSTRUCTIONS

**B.O.S.S.**  
BRICK ON SOFFIT SYSTEM

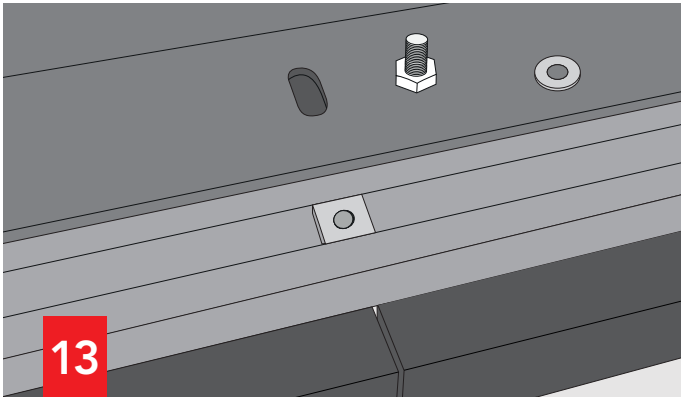

Insert spring nut into the channel at slotted hole centres.

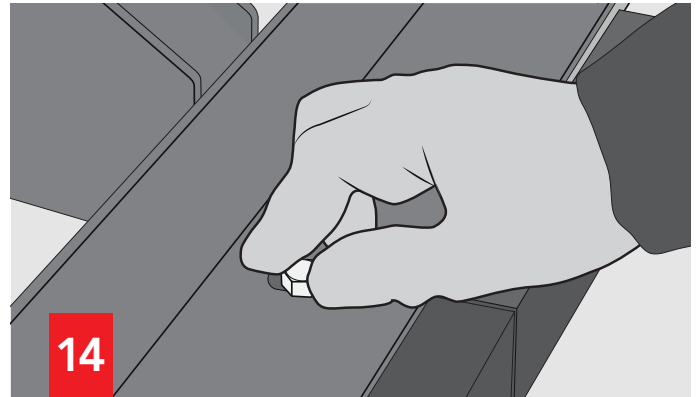

Offer BOSS unit up to WMS and insert bolt through slotted hole on the horizontal shelf picking up prepositioned spring nut in channel. Simply tighten the bolts by hand for now to allow further adjustment.

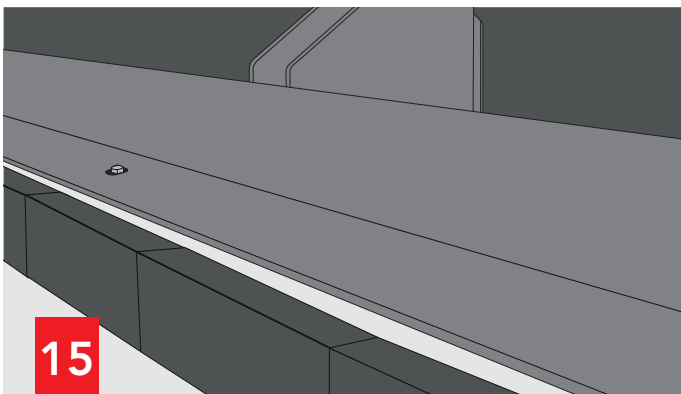

The BOSS unit can be moved left and right along the WMS to the desired location.

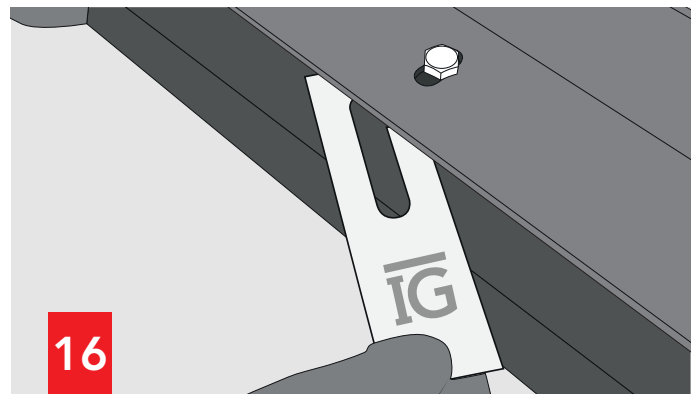

Further vertical adjustment is offered by inserting shims in between the WMS angle and BOSS unit.



Once the desired location is achieved torque the bolt to 20Nm.

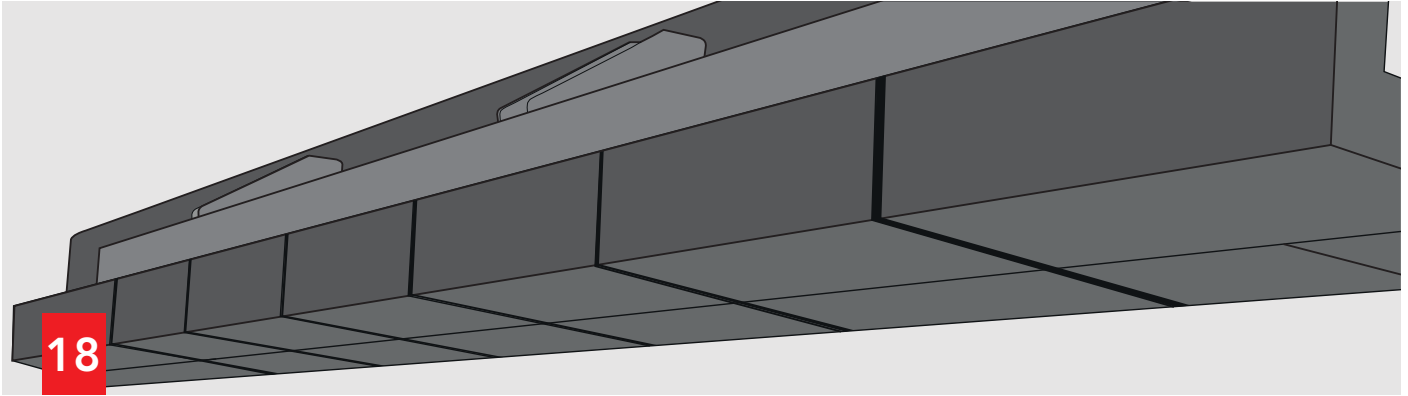

Locate neighbouring units, ensuring to leave the specified mortar gap between bricks on face and soffit.

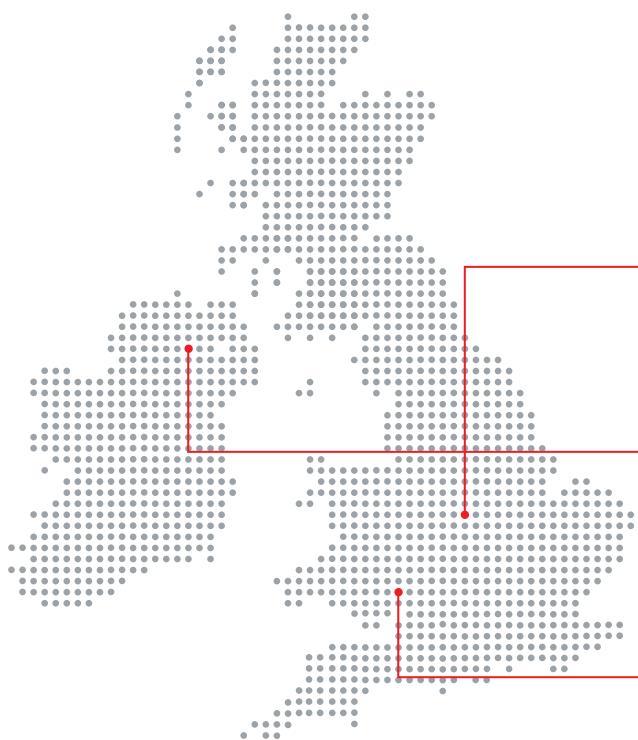

## MASONRY SUPPORT HOTLINE

# 01283 200 157

Email: [support@igmss.co.uk](mailto:support@igmss.co.uk)



### IG - SWADLINCOTE

Ryder Close, Cadley Hill Industrial Estate  
Swadlincote, South Derbyshire DE11 9EU  
T: +44 (0) 1283 200 157  
F: +44 (0) 1283 226 616



### IG - IRELAND

Ballyreagh Industrial Estate,  
Cookstown, Co. Tyrone BT80 9DG  
T: +44 (0) 28 86760 334  
F: +44 (0) 28 86761 011  
E: [info@igmss.co.uk](mailto:info@igmss.co.uk)



### IG - CWMBRAN

Avondale Road, Cwmbran,  
Gwent, NP44 1XY  
T: +44 (0) 1633 486 486  
F: +44 (0) 1633 486 465