

TITAN SYSTEM Installation Instructions

The Titan System consists of a shelf angle, brackets, lock washers, shims and bolts.

Brackets are available to suit cavity widths ranging from 70mm to 150mm in 10mm increments. Brackets for larger cavity sizes are only available upon request.

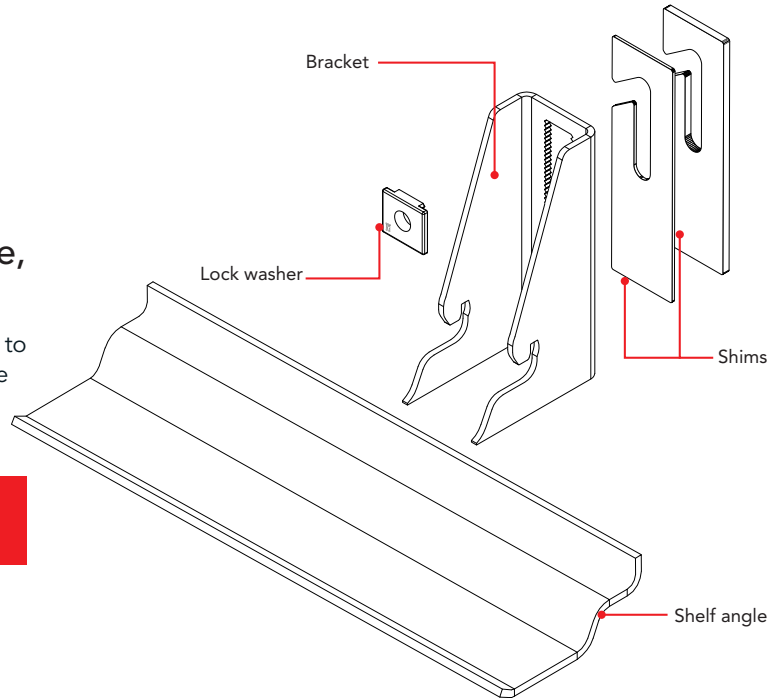

! To achieve the design capacity of the system, the product must be installed in the correct manner.

SUPPORT STRUCTURE

(The structure or beam that the Titan System is fixed to)

The suitability of the support structure is crucial to the performance of the Titan System. Please ensure the support structure is adequately designed by your main project engineer.

Before the Titan System is installed, the support structure must be checked for alignment and level. If the support structure is outside the adjustment range of the Titan System, outlined within this document, please consult with our Technical Team for advice.

BOLT REQUIREMENTS

The anchor bolt is the most important component involved in achieving the design capacity of the Titan System. It is crucial the bolts are installed in accordance with the manufacturer guidelines and torque settings (See Table 2) to ensure the design requirements for the product are met.

Only use specified bolts.

SAFETY

While Masonry Support Systems are easy to handle, components are produced from sheared plates and may have sharp edges. Care should be taken when handling masonry support components and suitable protective equipment should be worn at all times.



STORAGE

All goods received must be stored on a level area and cordoned off so that they are clearly visible. It is the manufacturer's recommendation that the goods stored on site should be covered. Cover should only be removed prior to installation.

MATERIALS

Bracket, Angle Section & Lock Washer:

304 austenitic stainless steel (EN 1.4301)

Isolators & Shims:

Nylon 66

Table 1

TITAN SYSTEM SPECIFICATION			
System Type	Unfactored Load (kN/m)	Angle Length (mm) *	Bracket Centres (mm)
TITAN 8	8	1190	600
TITAN 10	10	990	500
TITAN 12	12	990	500
TITAN 14	14	790	400

NOTE: Loadings may be restricted by cavity size and bolt type.
*Allowance for 10mm gap between shelf angles

Table 2

BOLT SPECIFICATION				
Bolt Type	Fixing To	Drill Hole Diameter	Torque (Nm)	Supplier Name
FBN II 12/20 A4	Concrete	12	35	Fischer
FAZ II 12/20 A4	Concrete	12	60	Fischer
RG M 12x120 A4	Concrete	14	40	Fischer
HD BOLT M12x60	Steel	12	30	Blindbolt
SET SCREW M12x60	Steel	14	73.5	Fit-Lock

LOAD BEARING ZONE ILLUSTRATION

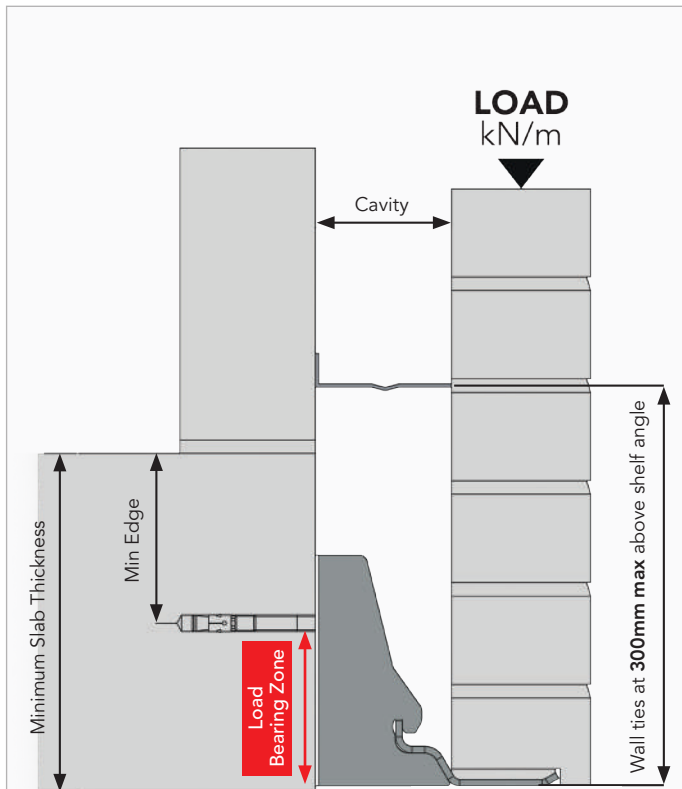

Figure 1
Key considerations for correct installation.

LOAD BEARING ZONE

Please note the load bearing zone in Figure 1. The bracket load bearing zone (ie the distance between the bolt and the bottom heel of the bracket) must have full contact with the support structure and shims. Reduction of the load bearing zone will reduce the design capacity of the system and may result in excessive deflection and bolt failure.

Never allow the heel of the bracket to project below the support structure. NB: If you require the bracket to drop below the support structure please contact the IG technical team.

BRICKWORK OVERHANG

Brickwork overhang must not exceed 1/3 of the brick width. A minimum masonry bearing of 2/3 on the shelf must be maintained unless otherwise stated by the manufacturer. It is therefore recommended that the bricks are positioned close to the back edge of the shelf angle (Figure 2).

WALL TIES

Stainless steel wall ties are crucial to the performance of all masonry support systems. Wall ties should be positioned at a maximum horizontal spacing of 450mm and should be placed within 300mm above and below the shelf angle (Figure 1).

IMPORTANT

POSITIONING THE BRACKET

Brackets must be installed at the correct level making sure the back of the bracket (load bearing zone) is in full contact with the support structure.

COMPRESSIBLE FILLER

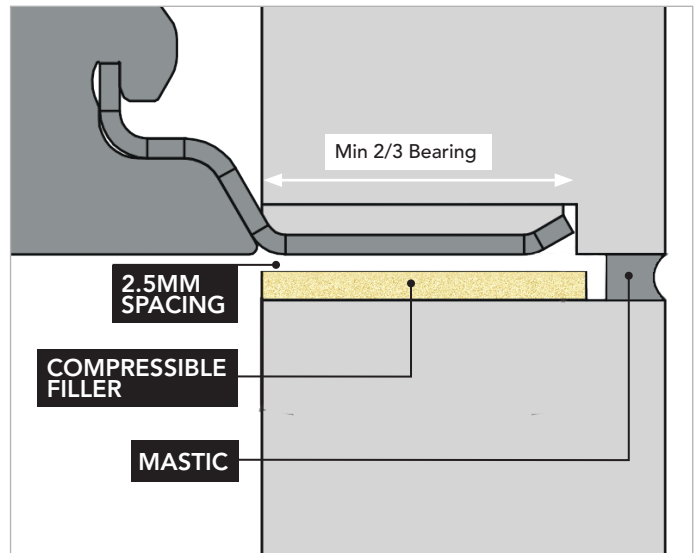

Figure 2

COMPRESSIBLE FILLER

It is essential that all soft horizontal joints have a compressible filler installed directly underneath the shelf angle.

POSITIONING THE SHELF

The underside of the shelf angle should be set 2.5mm above the level of the compressible filler to allow for any settlement that may occur as a result of the vertical dead load imposed by the masonry and to accommodate expansion of the brickwork below.

SHIMMING

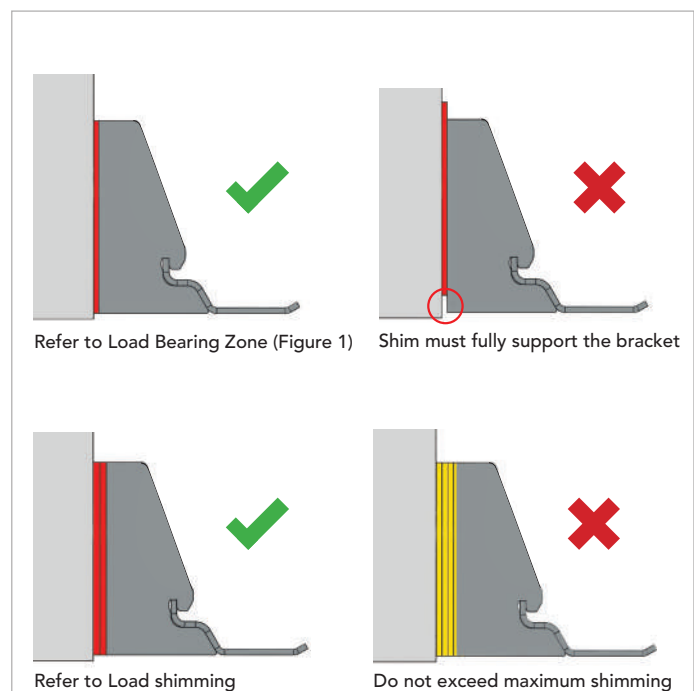
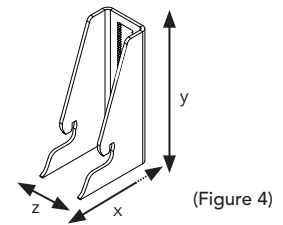

Figure 3

ADJUSTABILITY

IG Titan System provides adjustability across all three planes (Figure 4) to ensure that building tolerances can be accommodated and contact with reinforcing bar can be avoided.



LATERAL ADJUSTMENT (z)

Each Masonry Support System is designed to have two brackets per shelf angle (the only variation from this is on a corner where three brackets will be introduced). To achieve the correct bracket spacing, add 10mm to the shelf angle length and then space 1/4-1/2-1/4 along this measurement. The maximum adjustment from these positions is +/- 25mm (Figure 5). This allows the bracket position to be moved if the drill hole position clashes with reinforcing bar preventing drilling, or for pre drilled steel that is slightly offset from its required position.

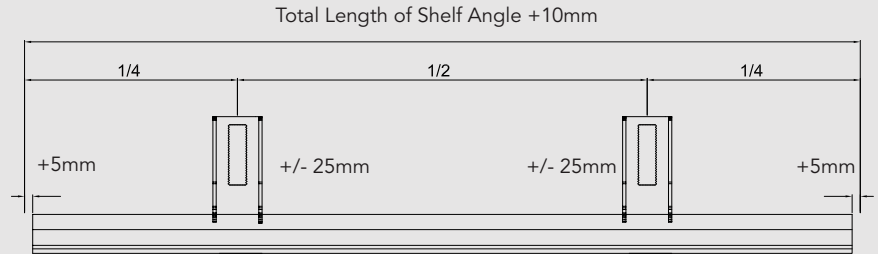

(Figure 5)

SHIMMING (x)

To accommodate a small increase in cavity width, shims can be inserted between the support structure and the bracket (Figures 3). Shims are available in 2mm and 6mm thicknesses. The combined thickness of shims used per bracket should never exceed the outside diameter of the bolt or 12mm, whichever is less. The collective number of shims that can be used should never exceed three number shims. Shims must support, and come into contact with the full load bearing zone of the bracket. 2mm Shims are provided as standard, 6mm Shims are available upon request.

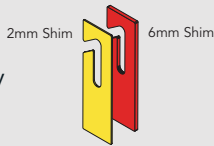

VERTICAL ADJUSTMENT (y)

Vertical adjustment is offered by means of a toothed Lock Washer (Figure 6). This Lock Washer is inserted into the serrated slot in the support bracket. The Lock Washer can be adjusted vertically to move the bracket higher or lower. The serrated area at the back of the bracket allows up to 22mm of adjustment in either direction on the vertical plane. The Lock Washer also gives fine adjustment by rotating it through 180°; this is achieved by the offset hole in the lock washer.

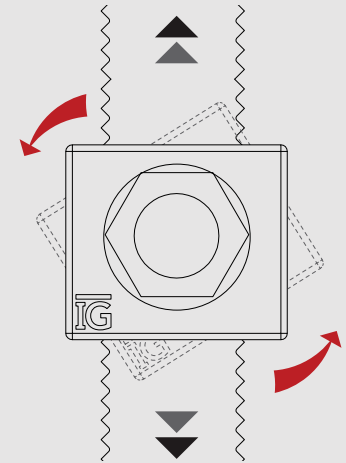

(Figure 6)

MAXIMUM CAVITY ADJUSTMENT WITH THE SAME BRACKET TYPE

The Titan System can accommodate on-site variations to a specified cavity width. Below are three examples of how the MSB-100 bracket specified for a 100mm cavity wall application can facilitate a variation in cavity width from 85mm to 115mm.

Section 85mm Cavity
MSB 100 Bracket

85mm cavity

Achieved using:
1No. 2mm shim & toothing of brick

Section 100mm Cavity
MSB 100 Bracket

100mm cavity

Achieved using:
1No. 2mm shim

Section 115mm Cavity
MSB 100 Bracket

115mm cavity

Achieved using:
2No. 6mm shims

EXTERNAL CORNERS

When installing IG Titan System at an external corner you need two mitred shelf angles. Each shelf angle consists of three support brackets and they are positioned as follows.

Bracket 1 is positioned 150mm in from the corner of the support structure.

Bracket 2 is positioned a further 150mm in from the centre of the first bracket.

Bracket 3 is positioned towards the other end of the shelf, drawings can be provided upon request.

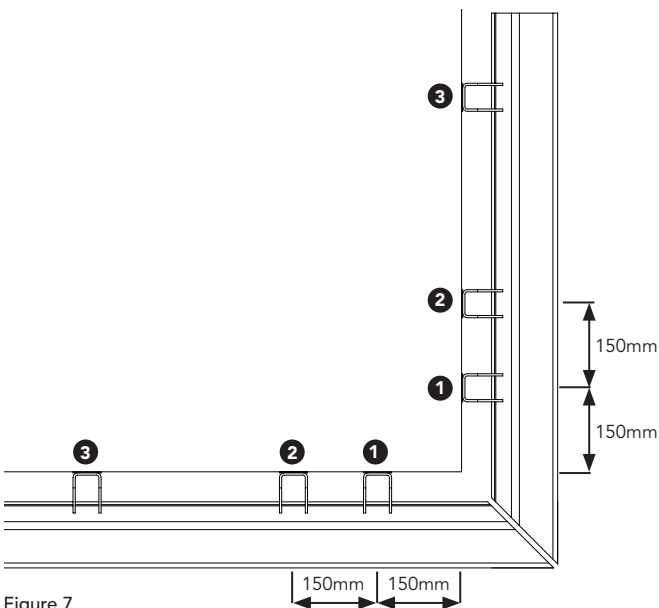

Figure 7

SITE CUTTING

IG Titan System's standard shelf angle can be cut on site to suit. Any cut or reduced length must still be supported by a minimum of 2 brackets. The minimum length that the shelf can be trimmed down to is 300mm with the minimum bracket spacing of 150mm. If the required space is less than 300mm then two shelves will have to be cut (Figure 8).

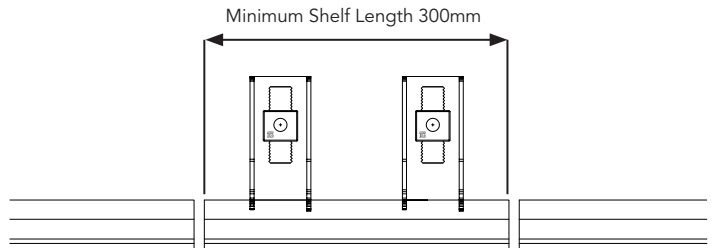

Figure 8

BI-METALLIC CORROSION

Bi-metallic corrosion can occur when stainless steel and carbon steel are in direct contact with each other in a damp environment. This can be avoided by isolating the two metals. IG Masonry Support Systems supply a thermal isolator shim as standard, that must be located between the back of the bracket and support beam. Top hat and neoprene washers are also available upon request.

REQUIRED BUILDING METHOD

One course of brick should be built on the masonry support shelf angle and given adequate time to cure. A further five courses of brickwork should then be built (which includes a DPC) and tied to the structure of the building, again given adequate time to cure. This will allow the masonry to form a rigid structure above the shelf angle.

The maximum height of masonry constructed each day above this rigid structure should not exceed 1500mm giving 1-2 days curing time before any future building.

• IG - CWMBRAN

Avondale Road, Cwmbran,
Gwent, NP44 1XY
T: +44 (0) 1633 486486
F: +44 (0) 1633 486465

• IG - IRELAND

Ballyreagh Industrial Estate,
Cookstown, Co. Tyrone BT80 9DG
T: +44 (0) 28 86760334
F: +44 (0) 28 86761011

• IG - SWADLINCOTE

Ryder Close, Cadley Hill Industrial Estate,
Swadlincote, South Derbyshire, DE11 9EU
T: +44 (0) 1283 200150
F: +44 (0) 1283 223352

MASONRY SUPPORT HOTLINE

01283 200 157

Email: support@igmss.co.uk

